



ENGLISH
GB (Original instructions)

OPERATOR'S MANUAL

CLEARING SAW

CLS-5800

⚠ WARNING



**READ THE INSTRUCTIONS CAREFULLY AND FOLLOW THE
RULES FOR SAFE OPERATION.
FAILURE TO DO SO COULD RESULT IN SERIOUS INJURY.**

Contents

For safe use of your product	3
Description	8
Before you start	9
Assembly	9
U-handle version.....	9
Adjusting the balance	11
Preparing the fuel	11
Engine operation.....	13
Starting the engine.....	13
Stopping the engine.....	14
Trimming operation	15
Using shoulder harness	16
Basic trimming operation with metal blade	16
Maintenance and care	18
Servicing guidelines.....	18
Maintenance and care	18
Storage	22
Specifications.....	23

For safe use of your product

Important information

⚠ WARNING

Please ensure that you read the operator's manual before using your product.

About your operator's manual

- This manual contains necessary information about the assembly, operation, and maintenance of your product. Please read it carefully and absorb its contents.
- Always keep your manual in a place where it is readily accessible.
- If you have lost your manual or it is damaged and no longer readable, please purchase a new one from your dealer.
- The units used in this manual are SI units (International System of Units). Figures in parentheses are reference values, and there may be a slight conversion error in some cases.
Failure to do so could lead to an accident or serious injury.

Intended use of this product

- This product is lightweight, high-performance, petrol engine unit designed for weed control, grass trimming and brush cutting in areas difficult to control by any other means.
- Do not use this unit for any purpose other than aforementioned.
- The content of this manual may be changed without notice for the purpose of upgrades to the product. Some of the illustrations used may differ from the product itself in order to make the explanations clearer.
- Please consult your dealer if anything is unclear or of concern.
Failure to do so could lead to an accident or serious injury.

Do not modify the product

- You must not modify the product.
To do so could lead to an accident or serious injury. Any malfunction resulting from a modification to the product will not be covered by the manufacturer's warranty.

Do not use the product unless it has been checked and maintained

- You must not use the product unless it has been checked and maintained. Always ensure that the product is checked and maintained on a regular basis.
Failure to do so could lead to an accident or serious injury.

Loaning or assigning your product

- When loaning your product to another party, ensure that the person borrowing the product receives the operator's manual along with it.
- If you assign your product to another party, please enclose the operator's manual with the product when handing it over.
Failure to do so could lead to an accident or serious injury.

Users of the product

- The product should not be used by:
 - ◆ people who are tired
 - ◆ people who have taken alcohol
 - ◆ people who are on medication
 - ◆ people who are pregnant
 - ◆ people who are in poor physical condition
 - ◆ people who have not read the operator's manual
 - ◆ children
- Keep in mind that the operator or user is responsible for accidents or hazards occurring to other people or their property.
Failure to observe these instructions could lead to an accident.



For safe use of your product

WARNING

Vibration and cold

- It is believed that a condition called Raynaud's Phenomenon which affects the fingers of certain individuals may be brought about by exposure to vibration and cold. Exposure to vibration and cold may cause tingling and burning, followed by loss of colour and numbness in the fingers. The following precautions are strongly recommended because the minimum exposure which might trigger the ailment is unknown.
 - ◆ Keep your body warm, especially the head and neck, feet and ankles, and hands and wrists.
 - ◆ Maintain good blood circulation by performing vigorous arm exercises during frequent work breaks, and also by not smoking.
 - ◆ Limit the number of hours of operation. Try to fill each day with jobs where operating the trimmer or other hand-held power equipment is not required.
 - ◆ If you experience discomfort redness and swelling of the fingers, followed by whitening and loss of feeling, consult your physician before exposing yourself further to cold and vibration.

Failure to observe these instructions could result in damage to your health.

Repetitive stress injuries

- It is believed that over-using the muscles and tendons of the fingers, hands, arms and shoulders may cause soreness, swelling, numbness, weakness and extreme pain to the areas just mentioned. Certain repetitive hand activities may put you at a high risk for developing a repetitive stress injury (RSI). To reduce the risk of RSI, do the following:
 - ◆ Avoid using your wrist in a bent, extended or twisted position.
 - ◆ Take periodic breaks to minimize repetition and rest your hands. Reduce the speed and force in which you do the repetitive movement.
 - ◆ Do exercises to strengthen hand and arm muscles.
 - ◆ See a doctor if you feel tingling, numbness or pain in your fingers, hands, wrists or arms. The sooner RSI is diagnosed, the more likely permanent nerve and muscle damage can be prevented.

Failure to observe these instructions could result in damage to your health.

Proper training

- Do not permit operation without proper training and protective equipment.
- Be thoroughly familiar with the controls and proper use of unit.
- Know how to stop the unit and shut off the engine.
- Know how to unhook a harnessed unit quickly.
- Never allow anyone to use the unit without proper instruction.

Failure to observe these instructions could result in damage to your health.

Wear proper clothing.

- Secure hair so it is above shoulder length.
- Do not wear ties, jewellery, or loose, dangling clothing which could be caught in the unit.
- Do not wear open toed footwear, or go bare-foot or barelegged.

Failure to observe these precautions could result in damage to your sight or hearing, or lead to a serious injury.



Wear protective gear

- Always wear the following protective gear when working with the trimmer.
 1. Head protection (helmet): Protects the head
 2. Ear muffs or ear plugs: Protect the hearing
 3. Safety goggles: Protect the eyes
 4. Face shield: Protects the face
 5. Safety gloves: Protect the hands from cold and vibration
 6. Work clothes that fit (long sleeves, long trousers): Protect the body
 7. Heavy duty, non-slip protective boots (with toecaps) or non-slip work shoes (with toecaps): Protect the feet
 8. Shin guards: Protect the legs

Failure to observe these precautions could result in damage to your sight or hearing, or lead to a serious injury.

- When necessary, please use the protective gear below.

- ◆ Dust mask: Protects the breathing apparatus
- ◆ Bee net: To deal with attacks by bees

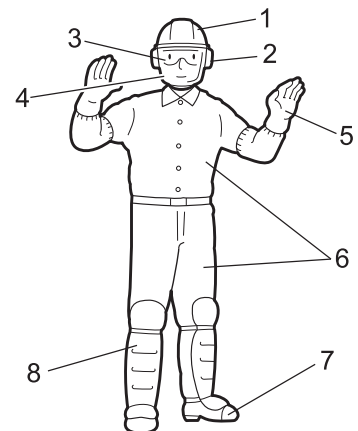

For safe use of your product

WARNING

Environment of use and operation

- Do not use the product:
 - ◆ under poor weather conditions.
 - ◆ on steep slopes or in places which give no secure foothold and are thus slippery.
 - ◆ at night or in dark places with poor visibility.
- When using the product on a gentle slope, work in a level, contour-like motion.
A serious injury could result if you fall or slip, or fail to operate the product correctly.
- For your own health and your safe and comfortable work, operate the machine within the air temperature range of -5°C to 40°C .
Failure to observe these instructions could result in damage to your health.

Being prepared in case of an injury

- In the unlikely event of an accident or injury, please ensure that you are prepared.
 - ◆ First aid kit
 - ◆ Towels and wipes (to stop any bleeding)
 - ◆ Whistle or mobile phone (for calling outside help)
- If you are unable to perform first aid or call for outside help, the injury could worsen.

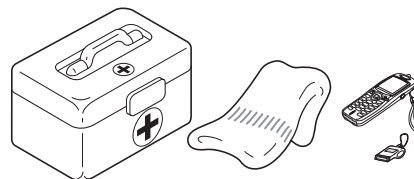

Put safety first in the case of fire or smoke

- If fire comes from the engine or smoke appears from any area other than the exhaust vent, first distance yourself from the product to ensure your physical safety.
 - Use a shovel to throw sand or other such material on the fire to prevent it from spreading, or put it out with a fire extinguisher.
- A panicked reaction could result in the fire and other damage becoming more extensive.



Warning notices

DANGER

This symbol accompanied by the word "**DANGER**" calls attentions to an act or a condition which will lead to serious personal injury or death of operators and bystanders.

WARNING

This symbol accompanied by the word "**WARNING**" calls attentions to an act or a condition which can lead to serious personal injury or death of operators and bystanders.

CAUTION

"**CAUTION**" indicates a potentially hazardous situation which, if not avoided, may result in minor or moderate injury.

Other indicators



Circle and slash symbol means whatever is shown is prohibited.



NOTE

This enclosed message provides tips for use, care and maintenance of the product.







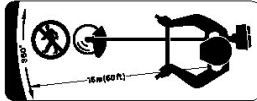





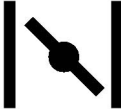

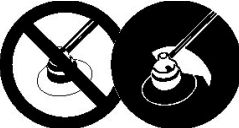

IMPORTANT

Framed text featuring the word "**IMPORTANT**" contains important information about the use, checking, maintenance and storage of the product described in this manual.

Symbols

Symbol form/shape	Symbol description/application	Symbol form/shape	Symbol description/application
	Carefully read the operator's manual		The maximum speed of the cutting attachment shaft in r/min
	Wear eyes, ears and head protection		Keep bystanders away 15 m

For safe use of your product

Symbol form/shape	Symbol description/applica- tion	Symbol form/shape	Symbol description/applica- tion
	Wear foot protection and gloves		Petrol and oil mixture
	Emergency stop		Choke Control "Cold Start" Position (Choke Closed)
	Warning! Thrown objects!		Choke Control "Run" Position (Choke Open)
	Warning, side thrust		Carburettor adjustment - Idle speed
	Usage without shield not per- mitted		U-handle
	Usage of metal blades not permitted		Loop handle
	Usage of nylon line cutting head not permitted		Beware of high-temperature areas
	Do not use the product in plac- es with poor ventilation		Guaranteed sound power lev- el
	Beware of fire		Engine start
	Beware of electric shocks		

For safe use of your product

Safety decal(s)

- The safety decal shown below has been attached to the products described in this manual. Ensure that you understand what the decal means before using your product.
- If the decal becomes unreadable due to wear and tear or damage, or peels off and is lost, please purchase a replacement decal from your dealer and attach it in the location shown in the illustrations below. Ensure that the decal is readable at all times.

1. Safety decal (Part number 890617-43130)

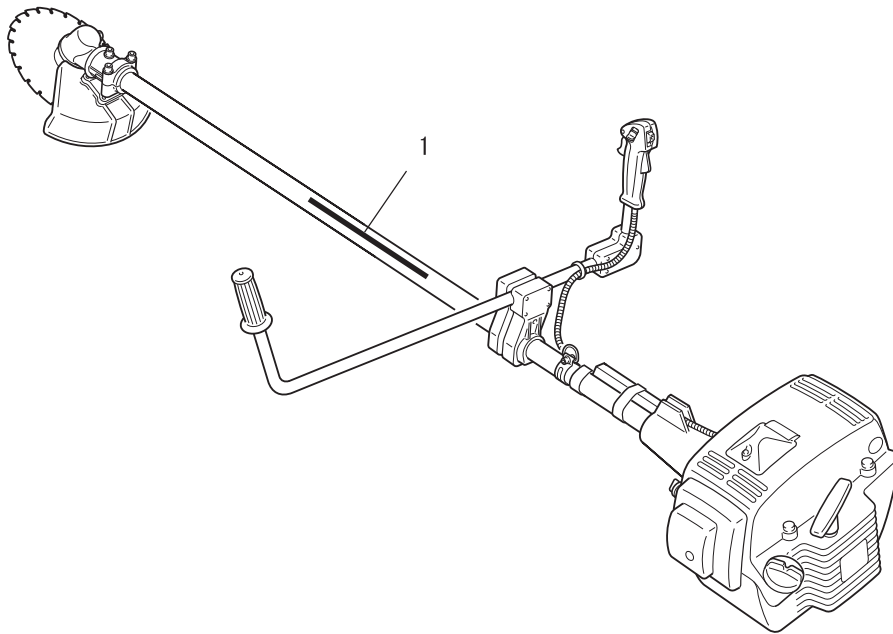
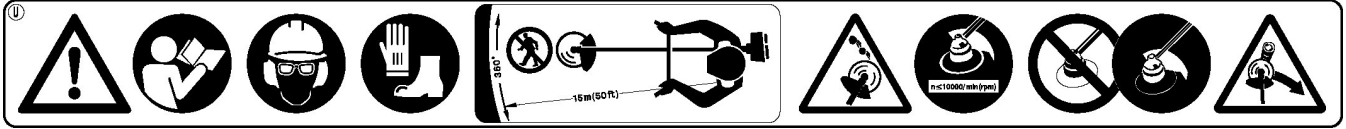

Description

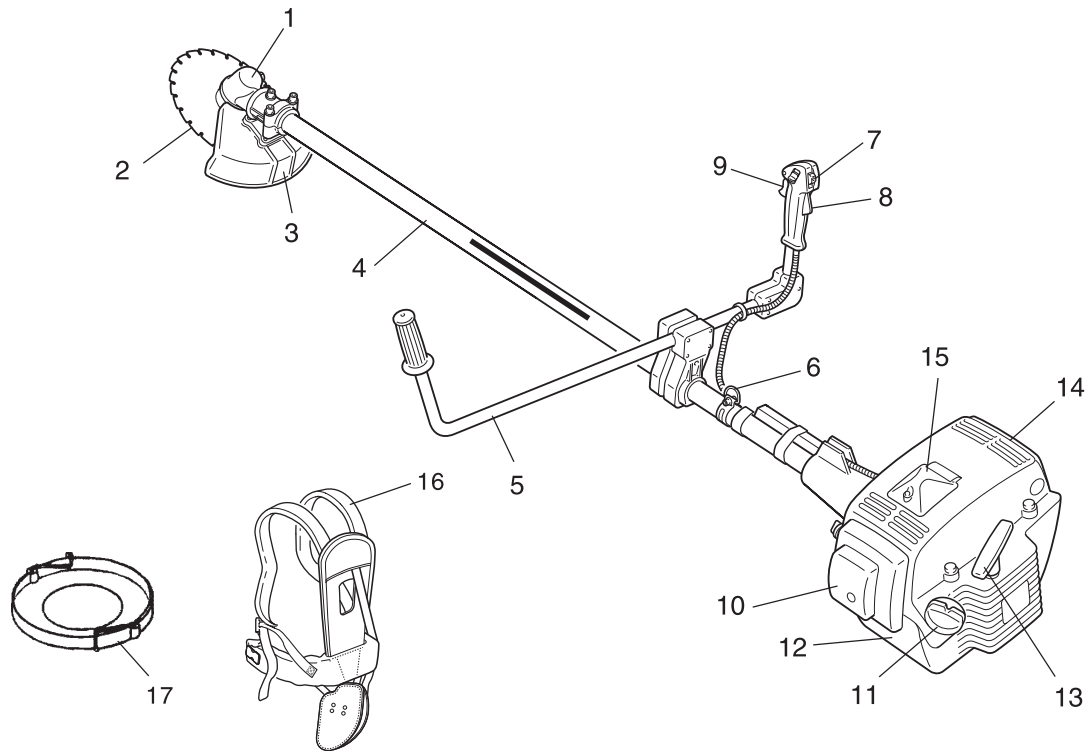

1. **Angle transmission** Having two gears to change the angle of rotating axis.
2. **Cutting attachment** Clearing blade for sawing heavy brush and small tree.
3. **Shield** Device to protect the operator from accidental contact with the cutting head and thrown objects.
4. **Shaft tube** Part of the unit that provides a casing for power transmission shaft.
5. **U-handle** Having the configuration of a bicycle handle bar to reduce working effort compared to a loop-handle.
6. **Suspension point** Device on which the harness can be hooked.
7. **Ignition switch** "Slide switch" mounted on top of the throttle trigger housing, move switch forward to RUN, backward to STOP position.
8. **Throttle trigger lockout** Locks throttle trigger in the idling position until you have a proper grip with your right hand around the handle.
9. **Throttle trigger** Activated by the operator's finger for controlling the engine speed.
10. **Air cleaner cover** Covers air filter.
11. **Fuel tank cap** For closing the fuel tank.
12. **Fuel tank** Contains fuel and fuel filter.
13. **Starter handle** Pull handle to start the engine.
14. **Silencer cover** Cover the silencer not to make operator touch the hot surface of silencer.
15. **Spark plug**
16. **Shoulder harness** An adjustable strap to suspend unit.
17. **Blade cover** When transporting the unit, use the appropriate metal blade cover.

Assembly

WARNING

- Read the operator's manual carefully to ensure that you assemble the product correctly.
Using a product that has been incorrectly assembled could lead to an accident or serious injury.



U-handle version Operation shaft assembly

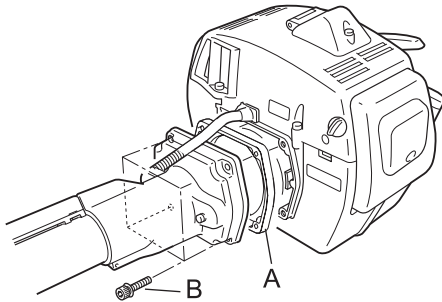

- ◆ Stand the engine upright on a level surface.
- ◆ With the spacer (A) placed in between, fit the operation shaft to the engine ensuring that it is correctly engaged.
- ◆ Fasten the operation shaft using the bolts (M5×30) (B) you can find in the same bag as the spacer.
- * The bolts (M5×25) packaged with the operation shaft are not used for this unit.

U-handle assembly

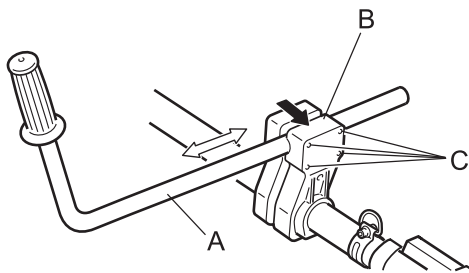

- ◆ Install the left handle (A) in the handle support (B) and fix it by lightly tightening bolts (M5×35) (C).
- ◆ Adjust inclination of handle to adequate position (easy to operate) and firmly tighten bolts (M5×35).

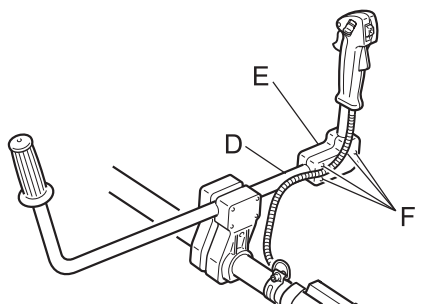

- ◆ Install the right handle (D) in the bracket (E).
- ◆ Position the handle in comfortable operating position and tighten bolts (M5×25) (F).

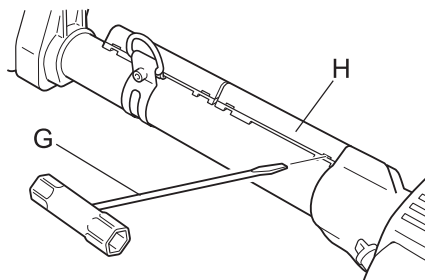

- ◆ Using a socket wrench (G), open the cable guide cover (H).

Before you start

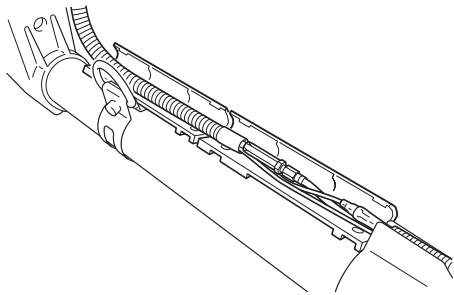

- ◆ Place the throttle cable inside the cable guide.
- ◆ Close the cover paying attention not to pinch the lead wire.

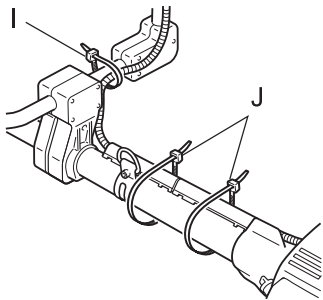

- ◆ Fix the throttle cable to the right handle with the band (short) (I).
- ◆ Hold the cable guide with the bands (long) (J) to prevent it from opening.

Installation of shield

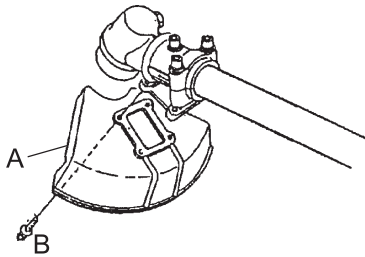

1. Fit shield (A) to mounting portion of angle transmission and tighten 4 bolts (B).

Installing blade

WARNING

- Wear heavy duty gloves when working with the trimmer blade.
 - When replacing the trimmer blade during a trimming task, ensure that the engine is switched off and that the blades have stopped.
 - When turning the product over to replace the trimmer blade, ensure that the fuel tank cap is securely in place.
 - Do not attempt to fit the trimmer blade with one hand or without using the socket spanner. Fit the trimmer blade accurately using the supplied socket spanner and tighten firmly in position.
 - Do not use any tools other than the provided socket spanner to tighten the blade; a pneumatic or electric tool may tighten the blade more than necessary and cause the nut or the output shaft to break.
 - If worn nut and cup for blade are used, there is a danger of blade getting loose. Replace them with new one.
- Failure to do so could lead to an injury or serious accident, or cause a fire.

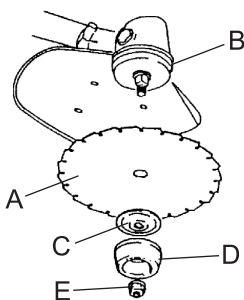

1. Inspect blades (C) before installation. Check for sharpness. Dull blades increase the risk of blade kickback reactions. Small cracks can develop into fractures resulting in a piece of blade flying off during operation. Discard cracked blades no matter how small the crack.
2. Use a locking tool to prevent the output shaft from turning during blade installation.
3. Install blade retainer (B), blade, lower blade retainer (C), cup washer (D) and nut (E) finger tight.
4. Tighten the nut (turn anticlockwise) using a socket wrench. Never fasten while applying your weight. Otherwise the thread of nut could be broken.

Before you start

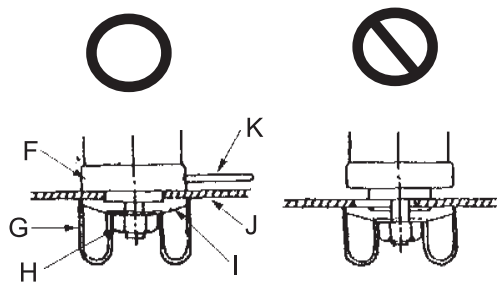

- F-Blade retainer
- G-Cup washer
- H-Nut
- I-Lower blade retainer
- J-Cutting attachment
- K-Locking tool

NOTE

Check to be sure the locking tool is fully engaged to prevent the output shaft from turning.

Adjusting the balance Adjusting the shoulder harness

⚠ WARNING

- This product is designed to fit a wide variety of body sizes, but may not be adjustable for extremely tall persons. Do not use the unit if your feet can reach the cutting attachment when the unit is attached to the harness.

IMPORTANT

- A person's size can affect the balancing adjustment. Also the balancing procedure may not work with some units on some persons. If the shoulder harness does not fit you or cannot be adjusted well, please ask your dealer for assistance.

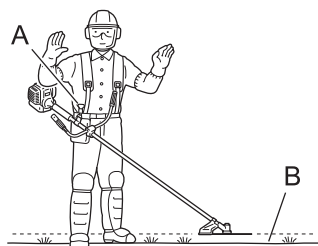

- ◆ Use a shoulder harness when provided or when recommended in this manual. Adjust both harness and the suspension point (A) on the unit so the unit hangs with the cutting attachment a few centimetres above ground level (B).
- ◆ The cutting attachment and shield should be level in all directions. Harness the unit on the right side as shown.

Balance tool for a level plane of cutting head rotation

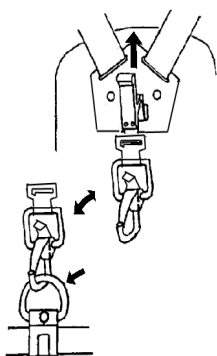

- ◆ Slide suspension point up and down the tube to find the right balance. Rotate the clamp to level the cutting attachment and shield. Lock in position. If the suspension point is a free-spinning type, the unit may tend to roll over sideways, however, you should still level the attachment and shield on the front-to-rear axis.
- ◆ Balancing and levelling, as above, may require relocation of the clamp and readjustment of the harness straps. Also, each type of cutting attachment and shield mounted on the unit may require balancing.

Preparing the fuel

⚠ DANGER

- Do not fuel up while the engine is hot or in operation.
- Do not smoke or hold a flame near when refuelling.
If you do so, the fuel could ignite and cause fire, leading to burns.



Before you start

WARNING

- Do not fill fuel tanks indoors. Always fill fuel tanks outdoors over bare ground. Do not refuel the product on the loading platform of a truck, or in other such places.
- Fuel tanks/cans may be under pressure. Always loosen fuel caps slowly allowing pressure to equalize. Otherwise, fuel may get spewed.
- Mop up any fuel that overflows or spills out due to overfilling. Fuel spills can cause fire and burns when ignited.
- After refuelling, always check that there are no leaks or discharges of fuel from the fuel pipe, fuel system grommets, or around the fuel tank cap. If you do find fuel leaks or discharges, stop using the product immediately and contact your dealer to have it repaired. Any fuel leaks could cause fire.
- Keep the refuelling tank in a shaded area away from fire.
- Use an approved fuel container.

IMPORTANT

- Fuel is a mixture of regular grade petrol and an air-cooled 2-stroke engine oil of reputable brand name. Minimum 89 Octane unleaded petrol is recommended. Do not use fuel containing methyl alcohol or more than 10 % of ethyl alcohol.
- Stored fuel ages. Do not mix more fuel than you expect to use in thirty (30) days.

Fuel

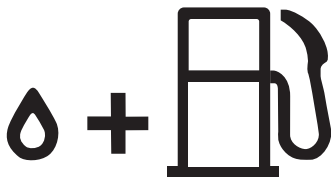

- ◆ Recommended mixture ratio; 50 : 1 (2 %) for ISO-L-EGD Standard (ISO/CD 13738), JASO FC,FD grade and ECHO Premium 50 : 1 oil.
- ◆ Do not mix directly in engine fuel tank.

Fuel supply

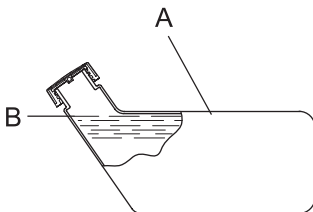

- ◆ Do not add so much fuel that it reaches the mouth of the fuel tank (A). Keep the fuel within the prescribed level (up to the shoulder level (B) of the fuel tank).
- ◆ Tighten the fuel tank cap securely after refuelling.

Starting the engine

WARNING

Be particularly careful to observe the following precautions when starting the engine:

- Move at least 3m from the place where you refueled.
 - Place the product in a flat, well ventilated place.
 - Check that there are no fuel leaks.
 - Inspect metal blades for cracks.
 - Check that none of the nuts and bolts are loose.
 - Leave plenty of space around the product and do not allow people or animals near it.
 - Start the engine with the throttle trigger in the idle speed position.
 - Hold the product firmly to the ground when starting the engine.
- Failure to observe the precautions could cause an accident or injury, or even lead to a fatality.

- Check that there are no abnormal vibrations or sounds once the engine starts. Do not use the product if there are abnormal vibrations or sounds. Contact your dealer to have it repaired.

Accidents involving parts that fall or shatter off can cause wounds or serious injury.

- The exhaust fumes from the engine contain toxic gases. Do not operate the product indoors or in other ill ventilated places.

The exhaust fumes could cause poisoning.



- Do not touch silencer, spark plug, angle transmission, and other high temperature components while the product is running or for some time after it stops.

You could burn yourself if you touch a high temperature component.



- Do not touch spark plug, spark plug wire, and other high voltage components while the product is running.

You could receive an electric shock if you touch a high voltage component while the product is running.



- If the cutting attachment rotates even though the throttle trigger is in the idle speed position when the engine is started, adjust the carburettor before using the product.

Failure to observe the precautions could cause an accident or injury, or even lead to a fatality.

- When starting engine using throttle latch, cutting attachment rotates. After engine starts, pull throttle trigger slightly to release throttle latch immediately. Never use throttle latch for operation.

The rotating blade can cause injury.

NOTE

- Pull out the starter grip gently at first, and then more rapidly. Do not pull the starter rope out to more than 2/3 of its length.
- Do not let go of the starter grip as it returns.

Starting a cold engine

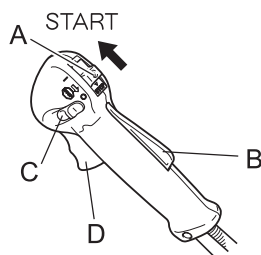

(Connect the spark plug cap if the product has been in storage for a long period of time.)

1. Remove the blade cover.
2. Placing the product on level ground, check to ensure that the cutting attachment does not come into contact with the surface of the ground or any other impediment using a beam or other such implement.
3. Move the ignition switch (A) to the Start position.
4. Make sure that the throttle trigger (D) is at the idle speed position.

Engine operation

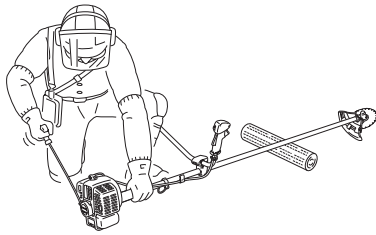
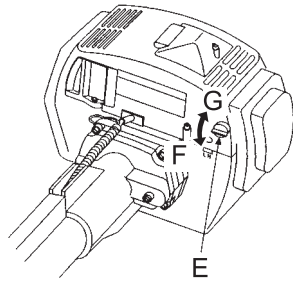

5. Move the choke knob (E) to the Closed position (F).
6. Checking that the area around you is safe, hold the position closest to the engine firmly as shown in the illustration, pulling several times on the starter grip.
7. If you hear an explosion-like sound and the engine stops immediately, move the choke knob to the Open position (G) and continue pulling on the starter grip to start the engine.
8. If the engine does not stop, return the choke knob gently to the Open position.
9. Leave the engine to warm up at idle speed for a while.

* When engine is hard to start, use throttle latch (C). (Pull throttle trigger fully and lower throttle latch while pressing throttle trigger lockout (B) and release throttle trigger to activate throttle latch. After engine starts, pull throttle trigger slightly to release throttle latch immediately.)

Starting a warm engine

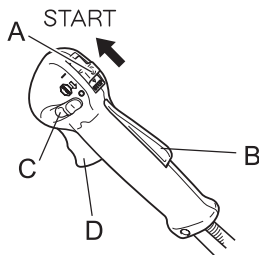

1. Move the ignition switch (A) to the Start position.
2. Make sure that the throttle trigger (D) is at the idle speed position.
3. Check that the choke knob is in the Open position.
4. Checking that the area around you is safe, hold the position closest to the engine firmly, and pull on the starter grip to start the engine.
5. If engine does not start after 4 pulls, use Cold Starting Procedure.

Stopping the engine

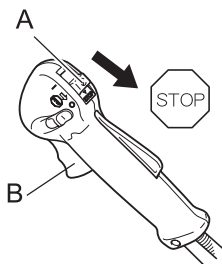

1. Move the throttle trigger (B) to the idle speed position and set the engine to idling (i.e. low speed).
 2. Move the ignition switch (A) to the Stop position.
 3. In the event of an emergency, stop the engine immediately using the ignition switch.
 4. If the engine fails to stop, move the choke lever to the "Cold Start" position. The engine will stall and come to a halt (an emergency stop).
- * If the engine fails to stop when the ignition switch is used, have the ignition switch checked and repaired by your dealer before you use the product again.
5. Always disconnect the spark plug wire from the spark plug to ensure the engine cannot be started before you work on the unit or leave it unattended.

Trimming operation

DANGER

- **Always stop the engine when a cutting attachment jam occurs.**
Severe injury can occur if a jam is removed and the cutting attachment suddenly starts.

- **Do not operate the product without the shield in place.**
Any objects that ricochet off the cutting attachment could cause an accident or serious injury.

- **The area within a 15 m radius of the product is a danger zone. Be careful to observe the following precautions while working with the product.**

- ◆ **Do not allow children and other people or pets to enter the danger zone.**
- ◆ **If another person enters the danger zone, turn off the engine to stop the cutting attachment from rotating.**
- ◆ **When approaching the operator, signal to him by, for example, throwing twigs from outside the danger zone, and then check that engine has been switched off and the cutting attachment has stopped turning.**
- ◆ **If more than one person is working with the product, identify the way in which you will signal to each other and work at least 15 m apart.**

Any objects that ricochet off the cutting attachment, and any contact with the cutting attachment, could cause blindness or a fatal accident.

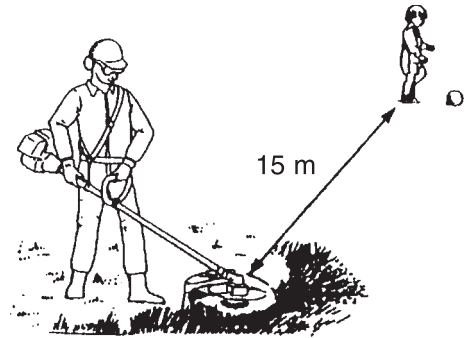

WARNING

- **Before starting work, check the area where you will be working and remove any small stones and empty cans likely to ricochet off the cutting attachment, as well as any pieces of string or wire that might become twisted around the cutting attachment.**

An accident or serious injury can occur if foreign objects ricochet off the cutting attachment or wire and other materials twisted round the product spring off it.



- **In the following situations, turn off the engine immediately and ensure that the cutting attachments have stopped before checking each area of the product. Replace any damaged parts.**

- ◆ **If the cutting attachment hits a rock, tree, post, or other such obstruction while you work.**
- ◆ **If the product suddenly starts to vibrate abnormally.**

Continuing to use parts when they are damaged could lead to an accident or serious injury.

- **Do not hold the cutting attachment up while you work. You must not work with the cutting attachments raised above knee level.**

Raising the cutting attachment above knee level brings the plane of rotation closer to the face, and any objects that fly off the cutting attachments could cause an accident or serious injury.

Transport of the product

- **When transporting in the situations described below, turn off the engine and ensure that the trimmer blade has stopped rotating, then fit the trimmer blade cover and position the silencer away from yourself.**

- ◆ **Moving to the place where you are working.**
- ◆ **Moving to another area while you are working.**
- ◆ **Leaving the place where you have been working.**

Failure to observe these precautions could cause burns or serious injury.

- **When transporting the product by car, empty the fuel tank, fit the blade cover, and secure the product firmly in place to prevent it from moving around.**

Travelling by car with fuel in the fuel tank could lead to a fire.

- **Never attempt to operate the product with one hand.**
- **Ensure that you hook your thumbs around the grips, wrapping them in your thumb and remaining fingers.**

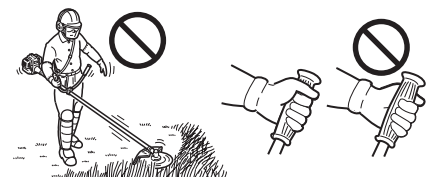

Trimming operation

Using shoulder harness

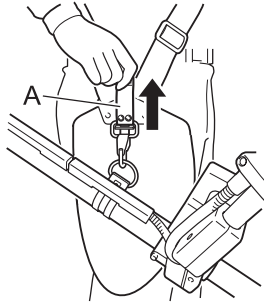

Always mount the trimmer correctly using the shoulder harness.

- ◆ Buckle waist belt. Belt should be snug.
- ◆ Attach product to harness.
- ◆ Place shoulder harness over both shoulders and adjust straps so the connecting point latches as shown.
- ◆ Check for correct adjustment by moving cutting attachment along ground.
- ◆ Re-adjust position of suspension point if necessary.
- ◆ The shoulder harness is fitted with an emergency release function. In the event of a fire or other emergency, pull the emergency tab (A) up to release the product from your body.

Basic trimming operation with metal blade

⚠ WARNING

- Please observe the following instructions when trimming.
 - ◆ Check to ensure that the trimmer blade has been tightened securely in place.
 - ◆ Replace the shield if it is damaged or cracked.
 - ◆ Replace the trimmer blade nut when it becomes worn.
 - ◆ Do not cut into the ground with the blade.
 - ◆ Do not operate with a dull, bent, fractured or discoloured blade and worn or damaged nut.
 - ◆ Do not run engine at full throttle without a load.

Failure to do so could lead to an accident or serious injury.

- Use only cutting attachments recommended by YAMABIKO CORPORATION.
- The type of blade used must be matched to the type and size of material cut. An improper or dull blade can cause serious personal injury. Blades must be sharp. Dull blades increase the chance of kick-out and injury to yourself and bystanders.
 - ◆ Plastic/Nylon Grass/Weed Blades may be used where ever the nylon line head is used. Do not use this blade for heavy weeds or brush.
 - ◆ The 3 cutter blade is designed especially to cut weeds and grass. To avoid injury due to kickback or blade fracture, do not use the 3 cutter blade to cut brush or trees.
 - ◆ 8 Tooth Weed/Grass Blade is designed for grass, garden debris and thick weeds. Do not use this blade for brush or heavy woody growth, 19 mm diameter or larger.
 - ◆ 22 Tooth Clearing Blade is designed for dense thickets and saplings up to 64 mm diameter.
 - ◆ 80 Tooth Brush Blade is designed for cutting brush and woody growth up to 13 mm diameter.

Damaged or shattered blades can cause accidents and serious injury.

Kickback

- The phenomenon that occurs if the trimmer blade comes into contact with a tree, post, rock or other hard object while rotating at high speed and reacts by recoiling powerfully and instantaneously is known as kickback.
- Causing kickback can result in a loss of control over the product and is highly dangerous.
- In particular, if the front-right quadrant of the trimmer blade (B) strikes a shrub or other such object, the trimmer blade will cause the product to recoil sharply backwards to the right.
- To prevent kickback, do not trim from left to right. Be careful to ensure that the trimmer blade does not strike any hard objects.
- When trimming, ensure that the object you are cutting meets the portion of the blade 1/3 in from the front edge on the left-hand side (A).

Failure to do so could cause an injury or fatal accident.

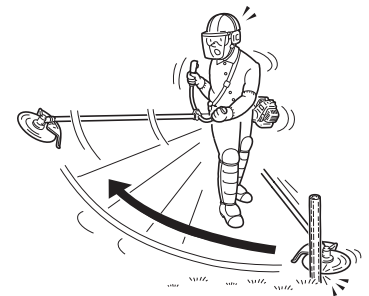
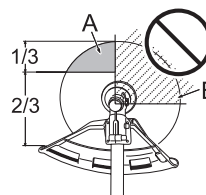

Trimming operation

Scything weeds



- ♦ This is cutting by swinging the cutting attachment in a level arc. It can quickly clear areas of field grass and weeds. Scything should not be used to cut large, tough weeds or woody growths.
- ♦ If a sapling or shrub binds the cutting attachment, do not use the cutting attachment as a lever to free the bind, because this will cause cutting attachment failure.
- ♦ Instead, shut off the engine and push the sapling or shrub to free the blades.

Maintenance and care

⚠ WARNING

Observe the following precautions when checking and maintaining your product after use:

- Turn the engine off and do not attempt to check or maintain the product until the engine has cooled.
You could burn yourself.
- Remove the spark plug cap before performing checks and maintenance.
An accident could occur if the product starts unexpectedly.

IMPORTANT

- Checking and maintenance requires specialist knowledge. If you are unable to check and maintain the product or deal with a fault yourself, consult your dealer. Do not attempt to dismantle the product.

Servicing guidelines

Area	Maintenance	Page	Before use	Monthly
Air filter	Clean/Replace	18	•	
Fuel filter	Inspect/Clean/Replace	19	•	
Spark plug	Inspect/Clean/Adjust/Replace	20		•
Carburettor	Adjust/Replace and adjust	19		•
Cooling system	Inspect/Clean	19	•	
Silencer	Inspect/Tighten	20	•	
Silencer	Clean	20		•**
Drive shaft	Grease	20		•**
Angle transmission	Grease	21		•*
Starter	Inspect	-	•	
Cut off knife	Inspect/Clean	-	•	
Fuel system	Inspect	19	•	
Screws, bolts and nuts	Inspect, Tighten/Replace	-	•	

* Or 50 hours, whichever occurs first. ** Or 100 hours, whichever occurs first.

IMPORTANT

- Time intervals are maximum. Actual use and your experience will determine the frequency of required maintenance.

Maintenance and care

If you have any questions or problems, please contact your dealer.

Cleaning air filter

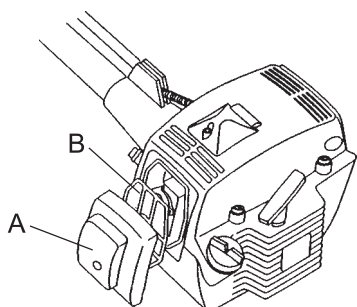

1. Close choke. Loosen screw and remove air cleaner cover (A).
2. Remove air filter (B) (air filter is located inside air cleaner cover).
3. Brush dirt from filter or clean with compressed air.
4. Reinstall filter.
5. Reinstall cover and tighten screw.

Maintenance and care

Replacing fuel filter

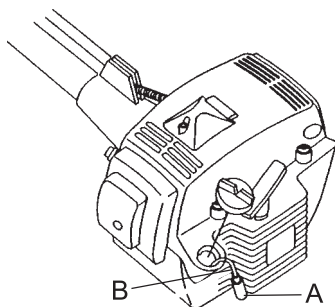

1. Use a piece of metal wire or the like to pick up fuel filter (A) through fuel tank opening.
2. Pull old filter from fuel line (B).
3. Install new fuel filter.

NOTE

- If filter is excessive dirty or no longer fits properly, replace it.

Carburettor adjustment

⚠ WARNING

- When the carburettor is being adjusted, the cutting attachment may move. Be careful not to get injured.

⚠ CAUTION

- When starting, idle speed adjustment screw (T) should be adjusted not to rotate the cutting attachment.
- When there is some trouble with the carburettor, contact your dealer.

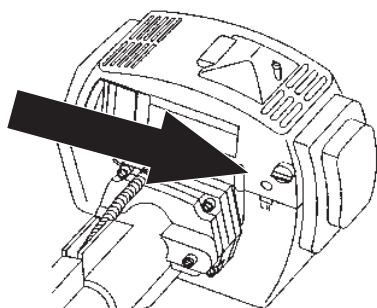
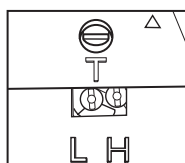

H: High speed mixture adjuster
L: Low speed mixture adjuster
T: Idle speed adjustment screw

Every unit is run at the factory and the carburettor is set in compliance with Emission Regulations. In addition, the carburettor is equipped with "H" (High Speed Needle) and "L" (Low Speed Needle) needle adjustment limiters that prevent settings outside acceptable limits.

1. Before adjusting carburettor clean or replace air filter and muffler.
2. Start engine and run several minutes to bring to operating temperature. Flash choke twice during warm-up to clear any air from the fuel system.
3. Stop engine. Turn "H" speed needle anticlockwise to stop. Turn "L" speed needle midway between full clockwise stop and anticlockwise stop.
4. Idle Speed Adjustment: . Start engine, turn "Idle" speed adjustment knob clockwise until the wheel begins to turn, then turn knob out anticlockwise until the wheel stops turning. Turn knob out, anticlockwise, an additional 1/4 turn.
5. Accelerate to full throttle for 2 - 3 seconds to clear any excess fuel in the engine, then return to idle. Accelerate engine to full throttle to check for smooth transition from idle to high speed. If engine hesitates turn "L" needle anticlockwise 1/8 turn and repeat acceleration. Continue adjustment until smooth acceleration results.
6. Check idle speed and reset if necessary as described in item 4. If a tachometer is available idle speed should be set as specified in the Operator's Manual.

Cooling system maintenance

IMPORTANT

- To maintain proper engine operating temperature, cooling air must pass freely through the cylinder fin area. This flow of air carries combustion heat away from the engine. Overheating and engine seizure can occur when:
 - ◆ Air intakes are blocked, preventing cooling air from reaching the cylinder.
 - ◆ Dust and grass build up on the outside of the cylinder. This build-up insulates the engine and prevents the heat from leaving.

Removal of cooling passage blockages or cleaning of cylinder fins is considered "Normal Maintenance". Any resultant failure attributed to lack of maintenance is not warranted.

Maintenance and care

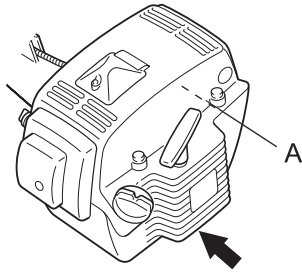

Air intake

- ♦ Remove dust and dirt from between fins (A).
- ♦ Before each use, remove accumulated debris from bottom engine intake grille located between the fuel tank and starter.

Cleaning silencer

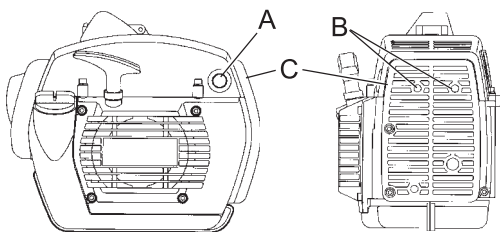

- ♦ Clean deposits from silencer (A) and tighten two bolts (B).

IMPORTANT

Do not remove the silencer cover (C). If necessary, Please consult your dealer.

Check fuel system

- ♦ Check before every use.
- ♦ After refuelling, make sure fuel does not leak or exude from around fuel pipe, fuel grommet or fuel tank cap.
- ♦ In case of fuel leakage or exudation there is a danger of fire. Stop using the machine immediately and request your dealer to inspect or replace.

Check spark plug

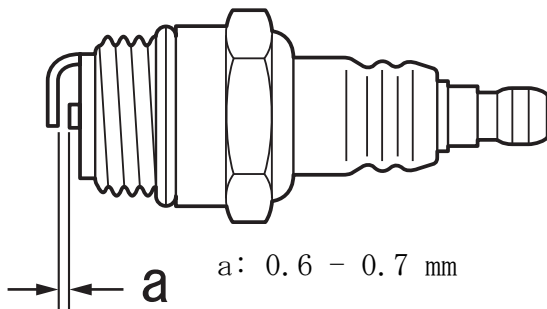

1. Check plug gap. Correct gap is 0.6 mm to 0.7 mm.
 2. Inspect electrode for wear.
 3. Inspect insulator for oil or other deposits.
 4. If the electrodes or terminals are worn, or if there are cracks in the ceramics, replace them with new parts.
 5. Tighten to 15 N·m - 17 N·m (150kgf·cm to 170 kgf·cm).
- * The spark test (for checking whether the spark plug is sparking) must be carried out by your dealer.

Lubricating drive shaft

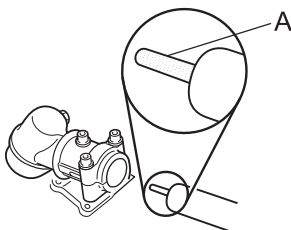

Inspect the drive shaft (A) every 100 hours of use and replenish grease if it is insufficient.

NOTE

Use good quality lithium multi grease.

Maintenance and care

Angle transmission

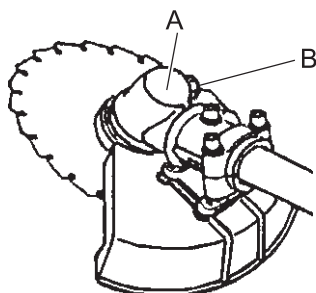

1. Remove plug (B) from angle transmission (A).
2. Add grease, if necessary, using low pressure pump.

NOTE

- Use good quality lithium multi grease.
- Do not overfill housing.

3. Reinstall plug.

Troubleshooting table

IMPORTANT

○ For spare parts and consumables, please use only genuine parts and designated products and components. Using parts from other manufacturers or non-designated components may result in a malfunction.

Problem	Diagnosis	Cause	Solution
The engine does not start		<ol style="list-style-type: none"> 1. There is no fuel in the fuel tank 2. The stop switch is in the Stop position 3. Excess fuel suction 4. Electrical fault 5. Carburettor malfunction or internal sticking 6. Internal engine malfunction 	<ol style="list-style-type: none"> 1. Fuel supply 2. Move to the Start position 3. Start the engine after servicing 4. Consult your dealer 5. Consult your dealer 6. Consult your dealer
Engine is difficult to start, fluctuating rotation	Fuel at carburettor	<ol style="list-style-type: none"> 1. Fuel degradation 2. Carburettor problem 	<ol style="list-style-type: none"> 1. Replace with new fuel 2. Consult your dealer
	No fuel at carburettor	<ol style="list-style-type: none"> 1. Fuel filter is clogged 2. Fuel system is clogged 3. Internal carburettor parts sticking 	<ol style="list-style-type: none"> 1. Clean or replace 2. Consult your dealer 3. Consult your dealer
	The spark plug is dirty or damp	<ol style="list-style-type: none"> 1. Fuel degradation 2. Incorrect electrode gap 3. Carbon deposits 4. Electrical fault 	<ol style="list-style-type: none"> 1. Replace 2. Replace 3. Replace 4. Consult your dealer
Engine starts but no acceleration is possible		<ol style="list-style-type: none"> 1. Dirty air filter 2. Dirty fuel filter 3. Blocked fuel passage 4. Carburettor adjustment problem 5. Blocked exhaust vent or silencer vent 	<ol style="list-style-type: none"> 1. Clean or replace 2. Clean or replace 3. Consult your dealer 4. Adjust 5. Clean
The engine stops		<ol style="list-style-type: none"> 1. Carburettor adjustment problem 2. Electrical fault 	<ol style="list-style-type: none"> 1. Adjust 2. Consult your dealer
The engine fails to stop		<ol style="list-style-type: none"> 1. Stop switch malfunction 	<ol style="list-style-type: none"> 1. Perform an emergency stop and consult your dealer
Cutting attachment rotates when the engine is idling		<ol style="list-style-type: none"> 1. Carburettor adjustment problem 2. Damaged clutch spring 	<ol style="list-style-type: none"> 1. Adjust 2. Consult your dealer

- ♦ Consult your dealer in the event of a problem that is not covered in the table above, or other such concerns.
- ♦ Please contact your dealer in order to dispose of the product or its parts in compliance with national laws.

Maintenance and care

Storage

Long-term storage (30 days or more)

WARNING

- Do not store in sealed locations filled with fuel gas, or close to naked flames or sparks. You could cause a fire.



When storing the product for long periods of time (30 days or more), ensure that the following preparations for storage are carried out.

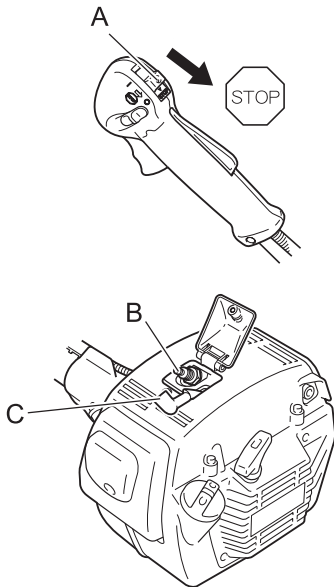

1. Remove any fuel from the fuel tank.
2. Start the engine and run it at idle speed until it comes to a natural stop.
3. Move the ignition switch (A) to the Stop position.
4. Once the product is sufficiently cool, wipe clean any grease, oil, dust, dirt and other materials on the outside of the trimmer.
5. Perform the periodic checks prescribed in this manual.
6. Check that the screws and nuts are tightened. Tighten up any that are loose.
7. Remove the spark plug (B) and add the appropriate quantity (around 10 mL) of clean, new 2-stroke engine oil to the cylinder via the installation socket.
8. Place a piece of clean cloth over the spark plug installation socket.
9. Pull 2 or 3 times on the starter grip to distribute the engine oil into the cylinder.
10. Observe the piston location through the spark plug hole. Pull the recoil starter handle slowly until the piston reaches the top of its travel and leave it there.
11. Fit the spark plug. (Do not connect the spark plug cap (C).)
12. Fit the blade cover onto the trimmer blade and wrap the engine section in a plastic bag or other covering, and store in a dry, dust-free location out of reach of children.

Specifications

	CLS-5800
External dimensions: Length × Width × Height	1705 × 700 × 475 mm
Mass: Unit without fuel, cutting attachment and guard (ISO11806) Unit with fuel, specified cutting attachment, guard and harness	10.2 kg 11.6 kg
Volume: Fuel tank	0.75 L
Cutting attachment: Usable cutting depth of specified cutting attachment Specified blade diameter Specified blade thickness Number of cutting teeth Blade centre hole diameter Blade rotational speed at maximum allowable engine speed	5 mm 200 mm 1.5 mm 22 20 mm 10000 r/min
Gear ratio: Gear ratio and lubrication	1.4 reduction and good quality lithium grease
Rotational direction of output shaft viewed from above:	Anticlockwise
Engine: Type Engine displacement Maximum shaft brake power, measured in accordance with ISO 8893 Engine speed at maximum engine power Recommended maximum engine speed (With STD attachment installed) Recommended engine idling speed Carburettor Ignition Spark plug Starter Clutch	Air cooled 2-stroke single cylinder 58.2 mL (cm ³) 2.42 kW 8500 r/min 11000 r/min 2500 r/min Diaphragm type Flywheel magneto - CDI system NGK BPMR8Y Recoil starter Automatic centrifugal clutch
Fuel: Oil Ratio Fuel consumption at maximum engine power Specific fuel consumption at maximum engine power	Regular grade petrol. Minimum 89 Octane unleaded petrol is recommended. Do not use fuel containing methyl alcohol or more than 10 % of ethyl alcohol. Two stroke, air-cooled engine oil. ISO-L-EGD Standard (ISO/CD 13738), JASO FC,FD grade and ECHO 50 : 1 oil. 50 : 1 (2%) 1.77 L/h 535 g/(kW·h)
Vibration levels: (ISO 22867) _{a_{hv,eq}}	Left handle 3.1 m/s ² Right handle 4.0 m/s ²
Sound pressure level: (ISO 22868) L _{pAeq}	99.2 dB(A)
Guaranteed sound power level: (ISO 22868) L _{WA}	115 dB(A)

These specifications are subject to change without notice.

YAMABIKO CORPORATION

7-2 SUEHIROCHO 1-CHOME, OHME, TOKYO 198-8760, JAPAN
PHONE: 81-428-32-6118. FAX: 81-428-32-6145.



X750-020760

X750226-5900

Printed in Japan
1402n 0329 ES