



EN ENGLISH

OPERATOR'S MANUAL

GRASS-TRIMMER/BRUSHCUTTER

SRM-520ES

 **WARNING**



**READ THE INSTRUCTIONS CAREFULLY AND FOLLOW THE
RULES FOR SAFE OPERATION.
FAILURE TO DO SO COULD RESULT IN SERIOUS INJURY.**

Contents

| | |
|---|----|
| For safe use of your product..... | 3 |
| Description..... | 8 |
| Before you start | 9 |
| Packing list | 9 |
| Assembly | 9 |
| U-handle version..... | 9 |
| With metal blade | 10 |
| Adjusting the balance | 11 |
| Preparing the fuel | 15 |
| Engine operation..... | 16 |
| Starting the engine | 16 |
| Stopping the engine..... | 17 |
| Trimming operation..... | 18 |
| Using shoulder harness | 19 |
| Basic trimming operation with nylon line cutting head | 19 |
| Basic trimming operation with metal blade | 21 |
| Maintenance and care | 22 |
| Servicing guidelines..... | 22 |
| Maintenance and care | 22 |
| Storage | 27 |
| Specifications..... | 28 |
| Declaration of conformity | 29 |

For safe use of your product

Important information

WARNING

Please ensure that you read the operator's manual before using your product.

About your operator's manual

- This manual contains necessary information about the assembly, operation, and maintenance of your product. Please read it carefully and absorb its contents.
- Always keep your manual in a place where it is readily accessible.
- If you have lost your manual or it is damaged and no longer readable, please purchase a new one from your dealer.
- The units used in this manual are SI units (International System of Units). Figures in parentheses are reference values, and there may be a slight conversion error in some cases.
Failure to do so could lead to an accident or serious injury.

Intended use of this product

- This product is lightweight, high-performance, petrol engine unit designed for weed control, grass trimming and brush cutting in areas difficult to control by any other means.
- Do not use this unit for any purpose other than aforementioned.
- The content of this manual may be changed without notice for the purpose of upgrades to the product. Some of the illustrations used may differ from the product itself in order to make the explanations clearer.
- Please consult your dealer if anything is unclear or of concern.
Failure to do so could lead to an accident or serious injury.

Do not modify the product

- You must not modify the product.
To do so could lead to an accident or serious injury. Any malfunction resulting from a modification to the product will not be covered by the manufacturer's warranty.

Do not use the product unless it has been checked and maintained

- You must not use the product unless it has been checked and maintained. Always ensure that the product is checked and maintained on a regular basis.
Failure to do so could lead to an accident or serious injury.

Loaning or assigning your product

- When loaning your product to another party, ensure that the person borrowing the product receives the operator's manual along with it.
- If you assign your product to another party, please enclose the operator's manual with the product when handing it over.
Failure to do so could lead to an accident or serious injury.

Users of the product

- The product should not be used by:
 - ◆ people who are tired
 - ◆ people who have taken alcohol
 - ◆ people who are on medication
 - ◆ people who are pregnant
 - ◆ people who are in poor physical condition
 - ◆ people who have not read the operator's manual
 - ◆ children
- Keep in mind that the operator or user is responsible for accidents or hazards occurring to other people or their property.
Failure to observe these instructions could lead to an accident.
- The ignition system of this product generates electromagnetic fields during operation. Magnetic fields can cause pacemaker interference or pacemaker failure. To reduce health risks, we recommend that pacemaker users consult their physician and the pacemaker manufacturer before operating this product.



For safe use of your product

WARNING

Vibration and cold

- It is believed that a condition called Raynaud's Phenomenon which affects the fingers of certain individuals may be brought about by exposure to vibration and cold. Exposure to vibration and cold may cause tingling and burning, followed by loss of colour and numbness in the fingers. The following precautions are strongly recommended because the minimum exposure which might trigger the ailment is unknown.
 - ◆ Keep your body warm, especially the head and neck, feet and ankles, and hands and wrists.
 - ◆ Maintain good blood circulation by performing vigorous arm exercises during frequent work breaks, and also by not smoking.
 - ◆ Limit the number of hours of operation. Try to fill each day with jobs where operating the trimmer or other hand-held power equipment is not required.
 - ◆ If you experience discomfort redness and swelling of the fingers, followed by whitening and loss of feeling, consult your physician before exposing yourself further to cold and vibration.

Failure to observe these instructions could result in damage to your health.

Repetitive stress injuries

- It is believed that over-using the muscles and tendons of the fingers, hands, arms and shoulders may cause soreness, swelling, numbness, weakness and extreme pain to the areas just mentioned. Certain repetitive hand activities may put you at a high risk for developing a repetitive stress injury (RSI). To reduce the risk of RSI, do the following:
 - ◆ Avoid using your wrist in a bent, extended or twisted position.
 - ◆ Take periodic breaks to minimize repetition and rest your hands. Reduce the speed and force in which you do the repetitive movement.
 - ◆ Do exercises to strengthen hand and arm muscles.
 - ◆ See a doctor if you feel tingling, numbness or pain in your fingers, hands, wrists or arms. The sooner RSI is diagnosed, the more likely permanent nerve and muscle damage can be prevented.

Failure to observe these instructions could result in damage to your health.

Proper training

- Do not permit operation without proper training and protective equipment.
- Be thoroughly familiar with the controls and proper use of unit.
- Know how to stop the unit and shut off the engine.
- Know how to unhook a harnessed unit quickly.
- Never allow anyone to use the unit without proper instruction.

Failure to observe these instructions could result in damage to your health.

Wear proper clothing.

- Secure hair so it is above shoulder length.
- Do not wear ties, jewellery, or loose, dangling clothing which could be caught in the unit.
- Do not wear open toed footwear, or go bare-foot or barelegged.

Failure to observe these precautions could result in damage to your sight or hearing, or lead to a serious injury.



Wear protective gear

- Always wear the following protective gear when working with the trimmer.
 1. Head protection (helmet): Protects the head
 2. Ear muffs or ear plugs: Protect the hearing
 3. Safety goggles: Protect the eyes
 4. Face shield: Protects the face
 5. Safety gloves: Protect the hands from cold and vibration
 6. Work clothes that fit (long sleeves, long trousers): Protect the body
 7. Heavy duty, non-slip protective boots (with toecaps) or non-slip work shoes (with toecaps): Protect the feet
 8. Shin guards: Protect the legs

Failure to observe these precautions could result in damage to your sight or hearing, or lead to a serious injury.

- When necessary, please use the protective gear below.

- ◆ Dust mask: Protects the breathing apparatus
- ◆ Bee net: To deal with attacks by bees

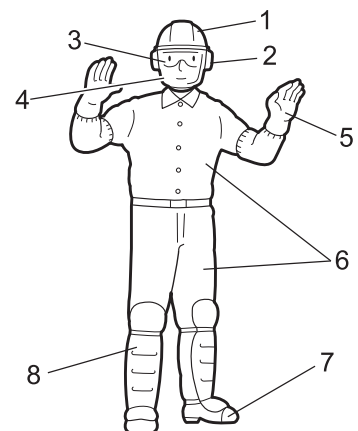

For safe use of your product

WARNING

Environment of use and operation

- Do not use the product:
 - ◆ under poor weather conditions.
 - ◆ on steep slopes or in places which give no secure foothold and are thus slippery.
 - ◆ at night or in dark places with poor visibility.
- When using the product on a gentle slope, work in a level, contour-like motion.
A serious injury could result if you fall or slip, or fail to operate the product correctly.
- For your own health and your safe and comfortable work, operate the machine within the air temperature range of -5°C to 40°C .
Failure to observe these instructions could result in damage to your health.

Being prepared in case of an injury

- In the unlikely event of an accident or injury, please ensure that you are prepared.
 - ◆ First aid kit
 - ◆ Towels and wipes (to stop any bleeding)
 - ◆ Whistle or mobile phone (for calling outside help)
- If you are unable to perform first aid or call for outside help, the injury could worsen.

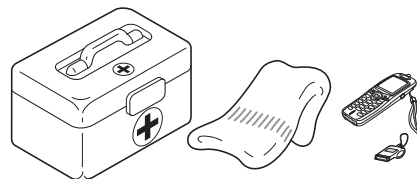

Put safety first in the case of fire or smoke

- If fire comes from the engine or smoke appears from any area other than the exhaust vent, first distance yourself from the product to ensure your physical safety.
 - Use a shovel to throw sand or other such material on the fire to prevent it from spreading, or put it out with a fire extinguisher.
- A panicked reaction could result in the fire and other damage becoming more extensive.



Warning notices

DANGER

This symbol accompanied by the word "**DANGER**" calls attentions to an act or a condition which will lead to serious personal injury or death of operators and bystanders.

WARNING

This symbol accompanied by the word "**WARNING**" calls attentions to an act or a condition which can lead to serious personal injury or death of operators and bystanders.

CAUTION

"**CAUTION**" indicates a potentially hazardous situation which, if not avoided, may result in minor or moderate injury.

Other indicators



Circle and slash symbol means whatever is shown is prohibited.



NOTE

This enclosed message provides tips for use, care and maintenance of the product.







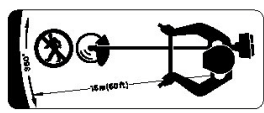







IMPORTANT

Framed text featuring the word "**IMPORTANT**" contains important information about the use, checking, maintenance and storage of the product described in this manual.

Symbols

| Symbol form/shape | Symbol description/application | Symbol form/shape | Symbol description/application |
|---|--------------------------------------|--|--|
|  | Carefully read the operator's manual |  | The maximum speed of the cutting attachment shaft in r/min |
|  | Wear eyes, ears and head protection |  | Keep bystanders away 15 m |

For safe use of your product

| Symbol form/shape | Symbol description/applica- tion | Symbol form/shape | Symbol description/applica- tion |
|---|--|--|--|
|  | Wear foot protection and gloves |  | Petrol and oil mixture |
|  | Emergency stop |  | Choke Control "Cold Start" Position (Choke Closed) |
|  | Warning! Thrown objects! |  | Choke Control "Run" Position (Choke Open) |
|  | Warning, side thrust |  | Carburettor adjustment - Idle speed |
|  | Usage without shield not permitted |  | U-handle |
|  | Usage of metal blades not permitted |  | Loop handle |
|  | Usage of nylon line cutting head not permitted |  | Beware of high-temperature areas |
|  | Do not use the product in places with poor ventilation |  | Guaranteed sound power level |
|  | Beware of fire |  | Engine start |
|  | Beware of electric shocks |  | Purge bulb (Primer) |

For safe use of your product

Safety decal(s)

- The safety decal shown below has been attached to the products described in this manual. Ensure that you understand what the decal means before using your product.
- If the decal becomes unreadable due to wear and tear or damage, or peels off and is lost, please purchase a replacement decal from your dealer and attach it in the location shown in the illustrations below. Ensure that the decal is readable at all times.

1. Safety decal (Part number 890617-43130)

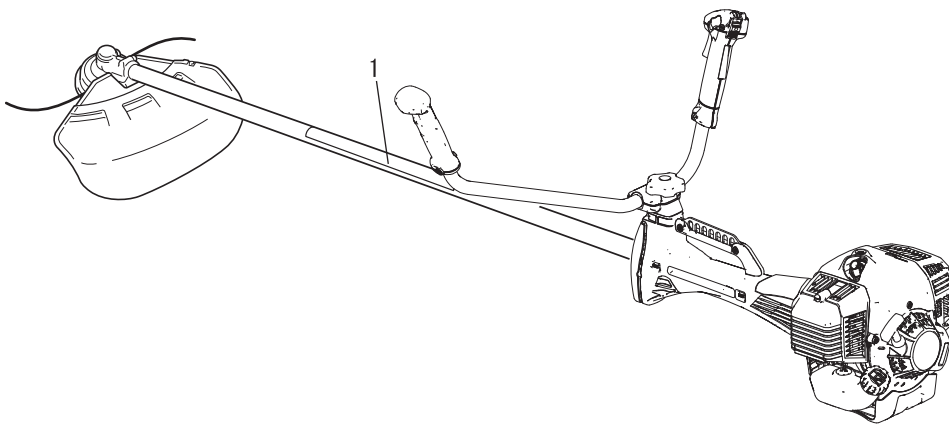
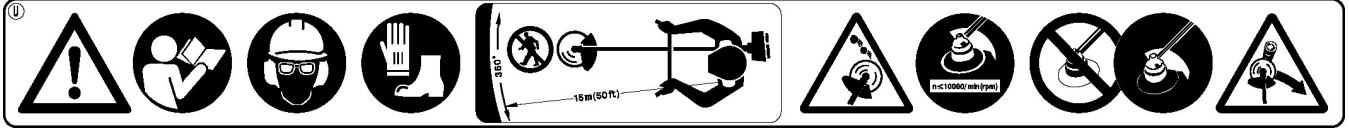

Description

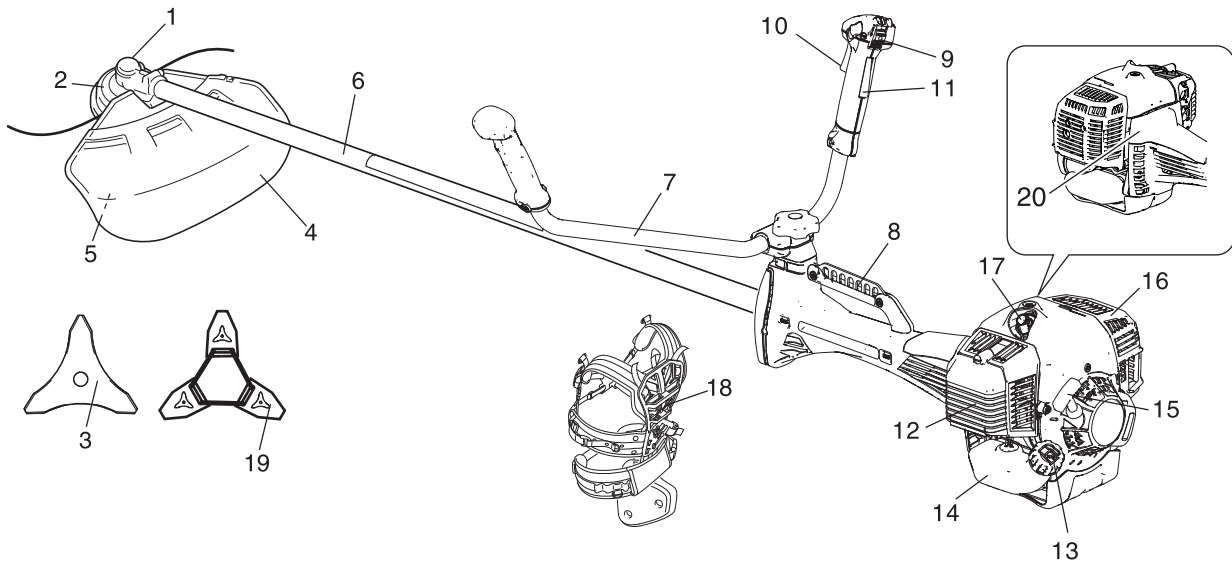

1. **Angle transmission** Having two gears to change the angle of rotating axis.
2. **Cutting attachment** Nylon line cutting head for cutting grass and weed.
3. **Cutting attachment** 3 cutter blade for cutting grass, garden debris and weeds.
4. **Shield** Device to protect the operator from accidental contact with the cutting head and thrown objects.
5. **Cut off knife** Cut nylon line to adjust line length to proper swath.
6. **Shaft tube** Part of the unit that provides a casing for power transmission shaft.
7. **U-handle** Having the configuration of a bicycle handle bar to reduce working effort compared to a loop-handle.
8. **Suspension point** Device on which the harness can be hooked.
9. **Ignition switch** "Slide switch" mounted on top of the throttle trigger housing, move switch forward to RUN, backward to STOP position.
10. **Throttle trigger** Activated by the operator's finger for controlling the engine speed.
11. **Throttle trigger lockout** Locks throttle trigger in the idling position until you have a proper grip with your right hand around the handle.
12. **Air cleaner cover** Covers air filter.
13. **Fuel tank cap** For closing the fuel tank.
14. **Fuel tank** Contains fuel and fuel filter.
15. **Starter handle** Pull handle to start the engine.
16. **Silencer cover** Cover the silencer not to make operator touch the hot surface of silencer.
17. **Spark plug**
18. **Shoulder harness** An adjustable strap to suspend unit.
19. **Blade cover** When transporting the unit, use the appropriate metal blade cover.
20. **Type and serial number**

Before you start

Packing list

- ♦ The following parts are packed separately in the packing box.
- ♦ When you have unpacked the box, please check the parts that it contains.
- ♦ Contact your dealer if anything is missing or broken.

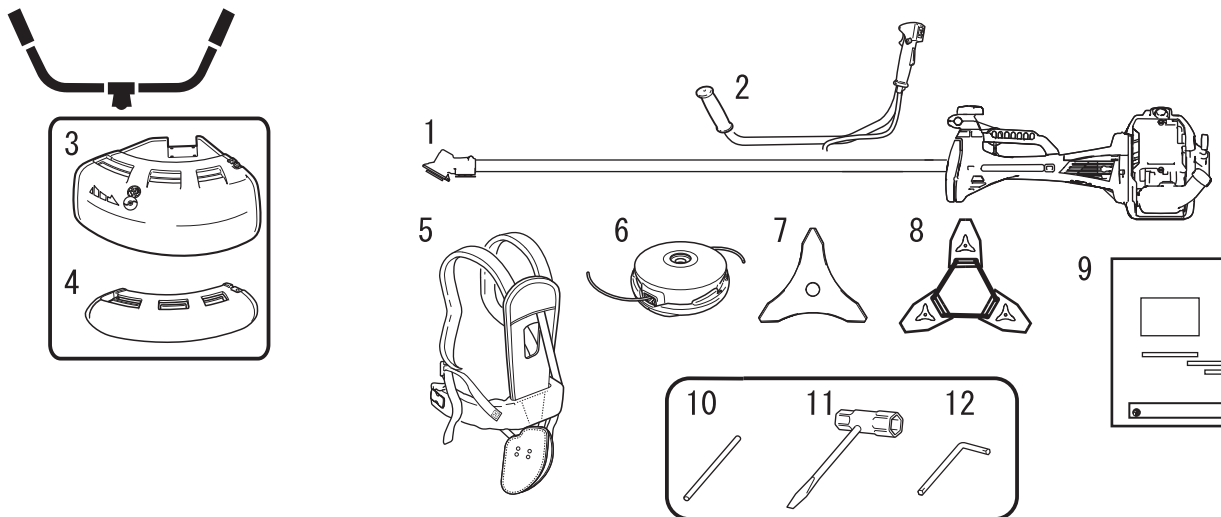

1. Engine and shaft tube
2. U-handle
3. Shield (for nylon line cutting head)
4. Shield (for metal blade)
5. Shoulder harness
6. Nylon line cutting head
7. 3 cutter blade
8. Blade cover
9. Operator's manual
10. Locking tool
11. Socket wrench
12. L-wrench

Assembly

WARNING

- Read the operator's manual carefully to ensure that you assemble the product correctly. Using a product that has been incorrectly assembled could lead to an accident or serious injury.



U-handle version U-handle assembly

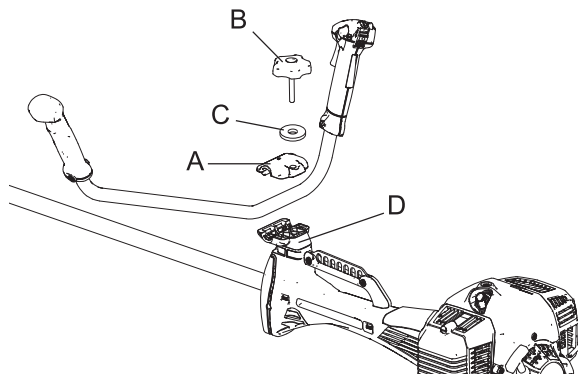

1. Install handle assembling bracket (upper) (A) in handle assembling bracket (lower) (D) and fix handle by tightening handle assembling bolt (8 mm) (B) lightly.
 2. Adjust inclination of handle to adequate position (easy to operate) and tighten firmly handle assembling bolt.
- C: Washer

Before you start

Installation of shield

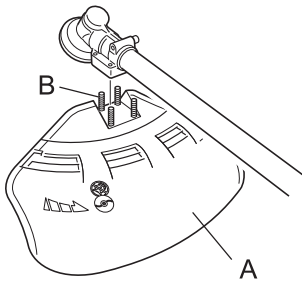

1. Fit shield (A) to mounting portion of angle transmission and tighten 4 bolts (B).

Installing nylon line cutting head

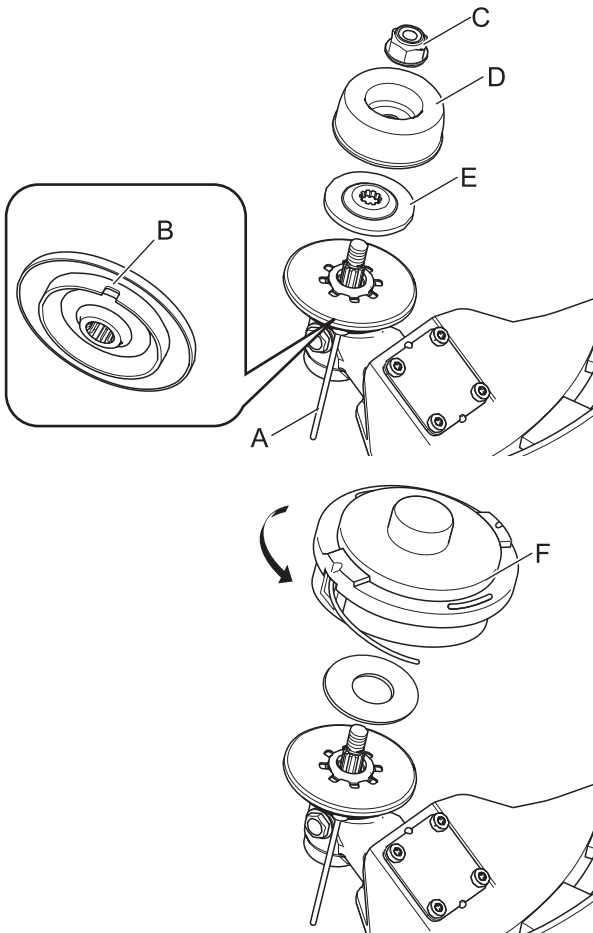

1. Insert locking tool (A) into a hole located on the right side of angle transmission while forcing retainer spring to the left side.
 2. Insert locking tool further into blade retainer fixing slot (B) to fix output shaft.
 3. Using the socket wrench, remove the nut (C), cup (D), and lower blade retainer (E).
- * Nut, cup, and lower blade retainer are not used with a nylon line cutting head.

CAUTION

○ Fix output shaft securely using locking tool in order to prevent it from rotating when nylon cutting head is mounted.

4. Thread nylon line cutting head (F) onto shaft (anticlockwise) until it is tight.
5. Remove locking tool.

With metal blade Method to change shield

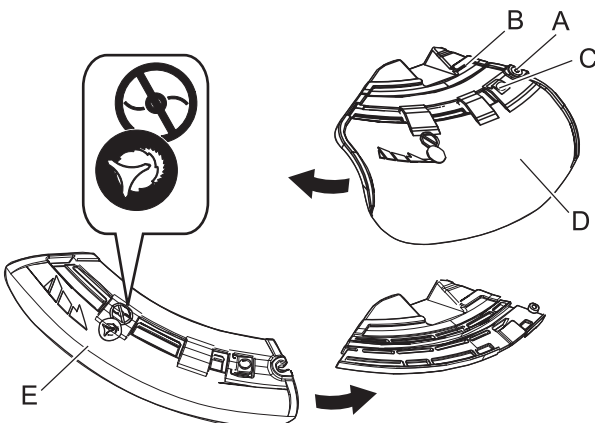

- ◆ There are two types of shields: namely the one used exclusively for nylon line cutting head and the other one used exclusively for metal blade. When metal blade is used, use the shield for metal blade.

1. Fully loosen the bolt (A) on the right side of the bracket (B) to slide the shield. The bolt itself cannot be removed from the bracket.
2. Pushing the button (C), slide the shield (D) to the left and remove it.
3. Put shield of other type (E) into groove and slide it to the right until it stops. Be sure to tighten the bolt.

Before you start

Installing blade

⚠ WARNING

- Wear heavy duty gloves when working with the trimmer blade.
- When replacing the trimmer blade during a trimming task, ensure that the engine is switched off and that the blades have stopped.
- When turning the product over to replace the trimmer blade, ensure that the fuel tank cap is securely in place.
- Do not attempt to fit the trimmer blade with one hand or without using the socket spanner. Fit the trimmer blade accurately using the supplied socket spanner and tighten firmly in position.
- Do not use any tools other than the provided socket spanner to tighten the blade; a pneumatic or electric tool may tighten the blade more than necessary and cause the nut or the output shaft to break.
- If worn nut and cup for blade are used, there is a danger of blade getting loose. Replace them with new one. Failure to do so could lead to an injury or serious accident, or cause a fire.

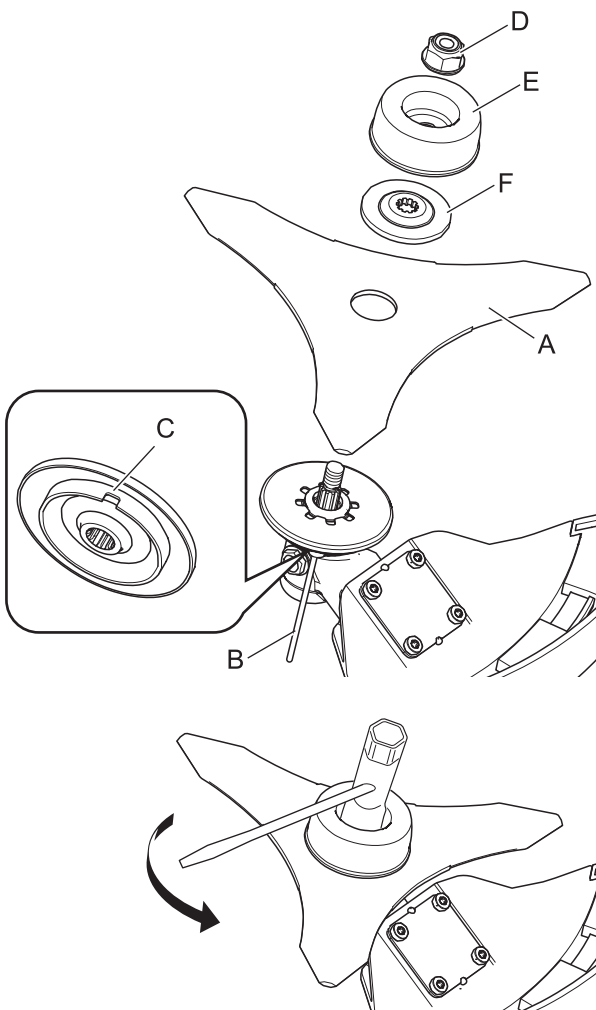

1. Inspect blades (A) before installation. Check for sharpness. Dull blades increase the risk of blade kickback reactions. Small cracks can develop into fractures resulting in a piece of blade flying off during operation. Discard cracked blades no matter how small the crack.
2. Insert locking tool (B) into a hole located on the right side of angle transmission while forcing retainer spring to the left side.
3. Insert locking tool further into blade retainer fixing slot (C) to fix output shaft.
4. Using the socket wrench, remove the nut (D), cup (E), and lower blade retainer (F).
5. Securely tighten the blade, lower blade retainer, cup, and nut by hand.

⚠ CAUTION

- Fix output shaft securely using locking tool in order to prevent it from rotating when blade is mounted. Otherwise, the blade fastening nut will not be tightened sufficiently.
6. Tighten the nut (turn anticlockwise) using a socket wrench. Never fasten while applying your weight. Otherwise the thread of nut could be broken.
 7. Remove locking tool.

Adjusting the balance Adjusting the shoulder harness

⚠ WARNING

- This product is designed to fit a wide variety of body sizes, but may not be adjustable for extremely tall persons. Do not use the unit if your feet can reach the cutting attachment when the unit is attached to the harness.

IMPORTANT

- A person's size can affect the balancing adjustment. Also the balancing procedure may not work with some units on some persons. If the shoulder harness does not fit you or cannot be adjusted well, please ask your dealer for assistance.

Before you start

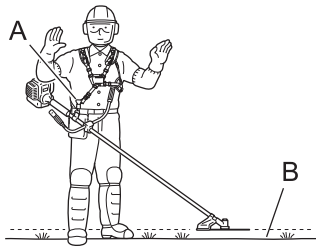

- ♦ The accompanying shoulder harness is suitable for people of standard adult physique, who are 150 cm - 195 cm in height and 60 cm - 140 cm in waist size.
- ♦ Use a shoulder harness when provided or when recommended in this manual. Adjust both harness and the suspension point (A) on the unit so the unit hangs with the cutting attachment a few centimetres above ground level (B).
- ♦ The cutting attachment and shield should be level in all directions. Harness the unit on the right side as shown.

Balance tool for a level plane of cutting head rotation

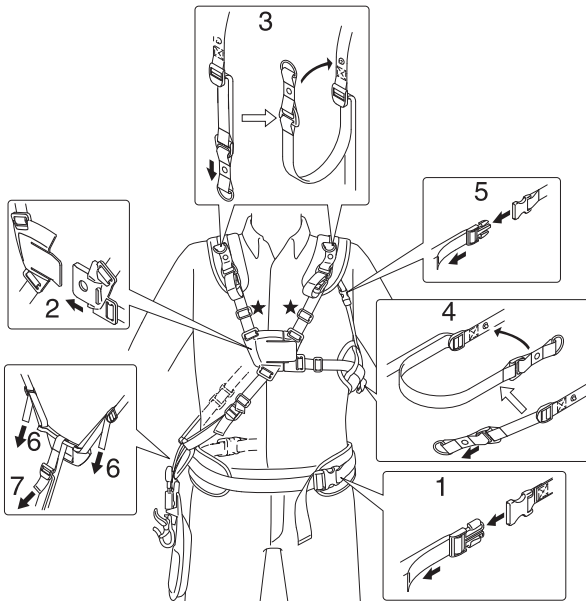

Harness fastening procedure

1. Fit the waist pad on your hipbone and then click the waist buckle in and pull the band to tighten the pad. It is recommended that the fitting position is just lower than your belt location.
2. Click the chest buckle together with the shoulder and chest band loosened.
3. Pull down the shoulder pad adjustment band to fasten on the shoulder pad tightly and then snap the band on the shoulder pad.
4. Pull the side pad adjustment band to fasten the side pad tightly and then snap the band on the side pad.
5. Click the fitting buckle together and then pull the fitting band down to fasten the left side shoulder pad and side pad tightly.
6. Adjust the hang plate height just on the waist pad.
7. Adjust the leg pad height to comfortable height for the unit operation.

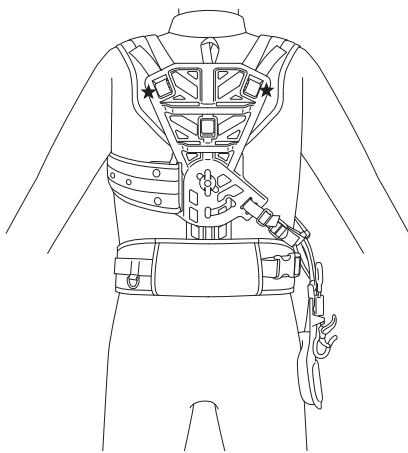

NOTE

- If you still feel too tight or too loose after the above adjustment procedure, adjust the total length of the harness to fit your body by adjusting the part of the star marks.

Before you start

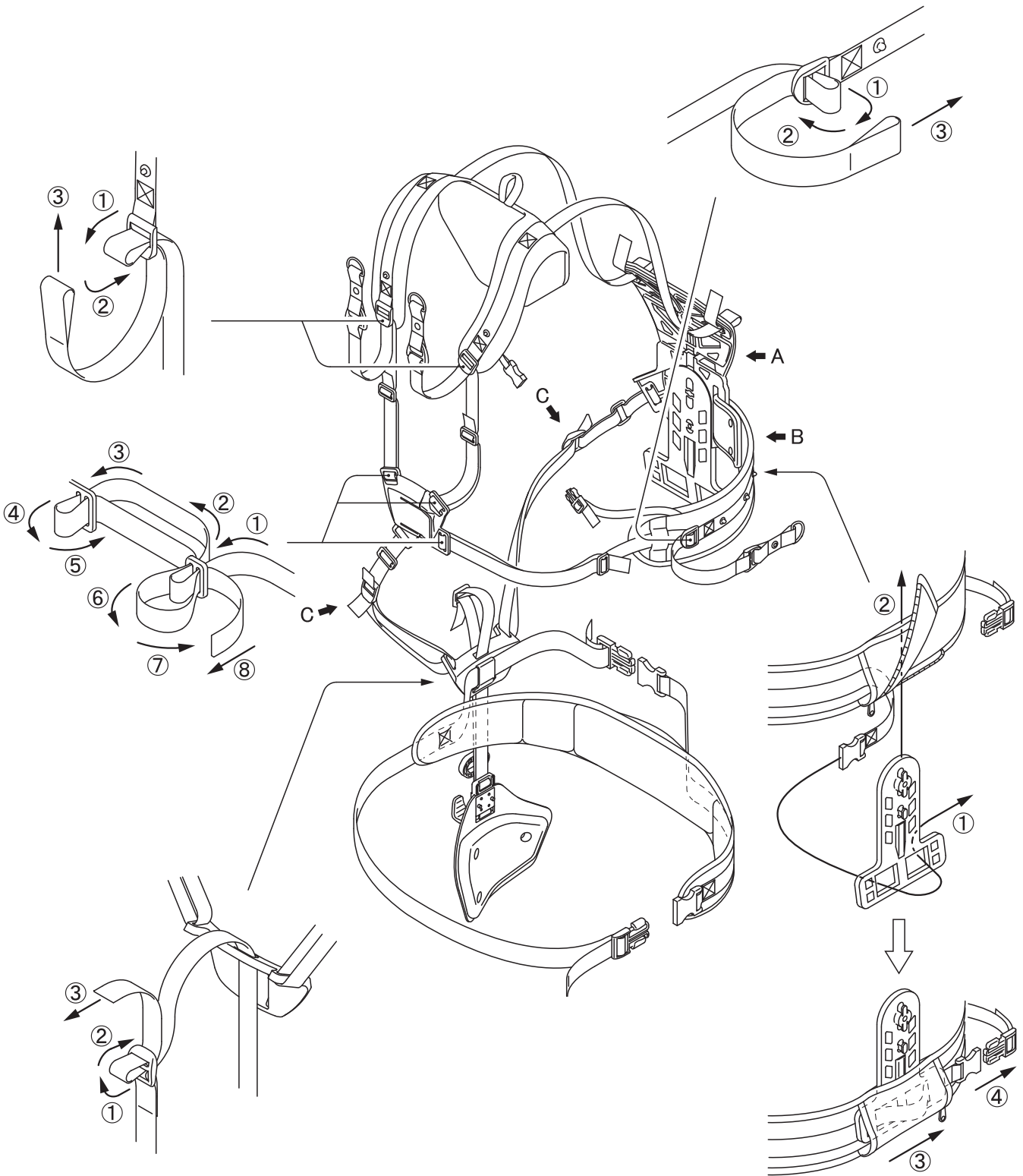

NOTE

○ If you replace the band, attach it as shown in the illustration.

Before you start

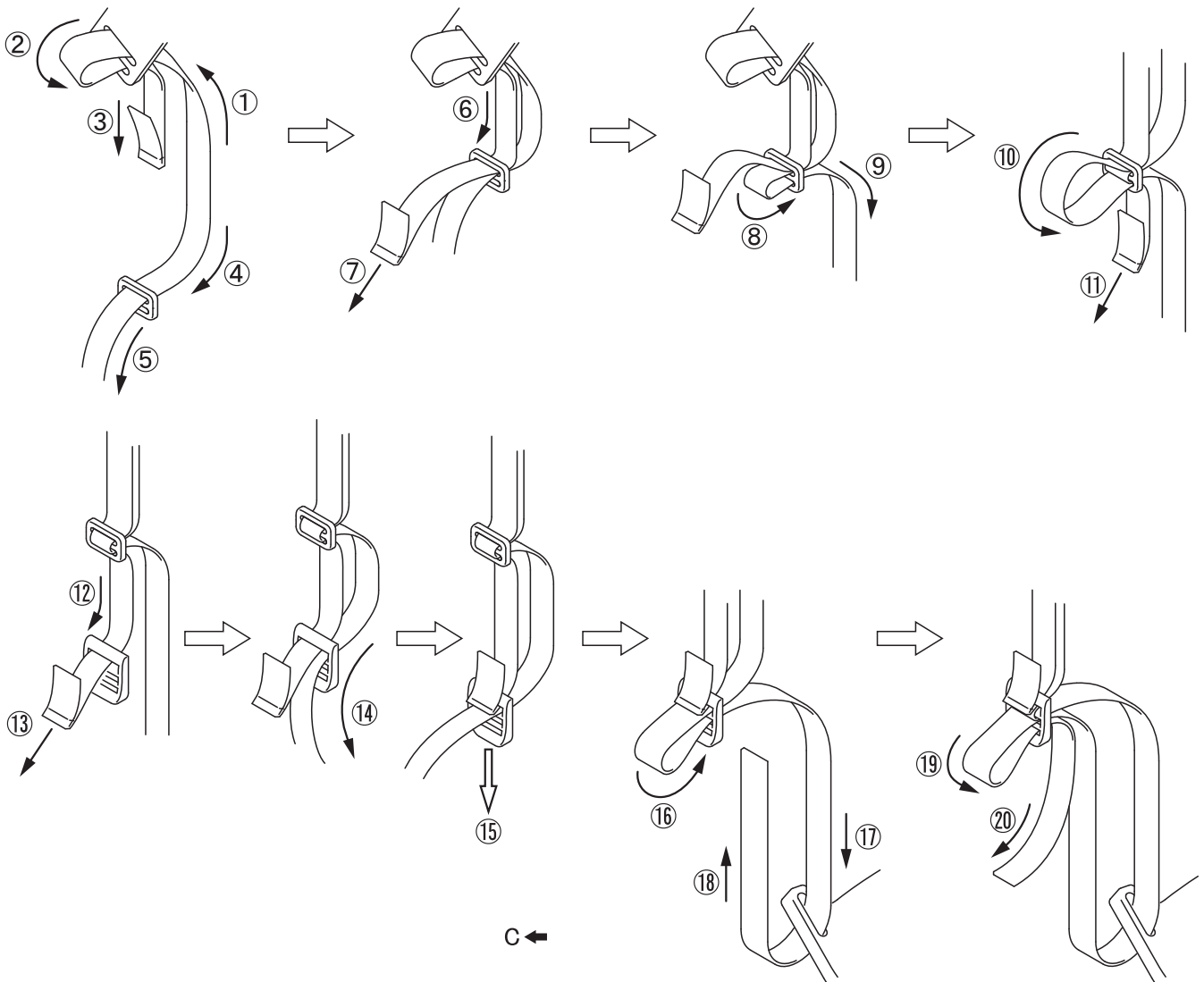
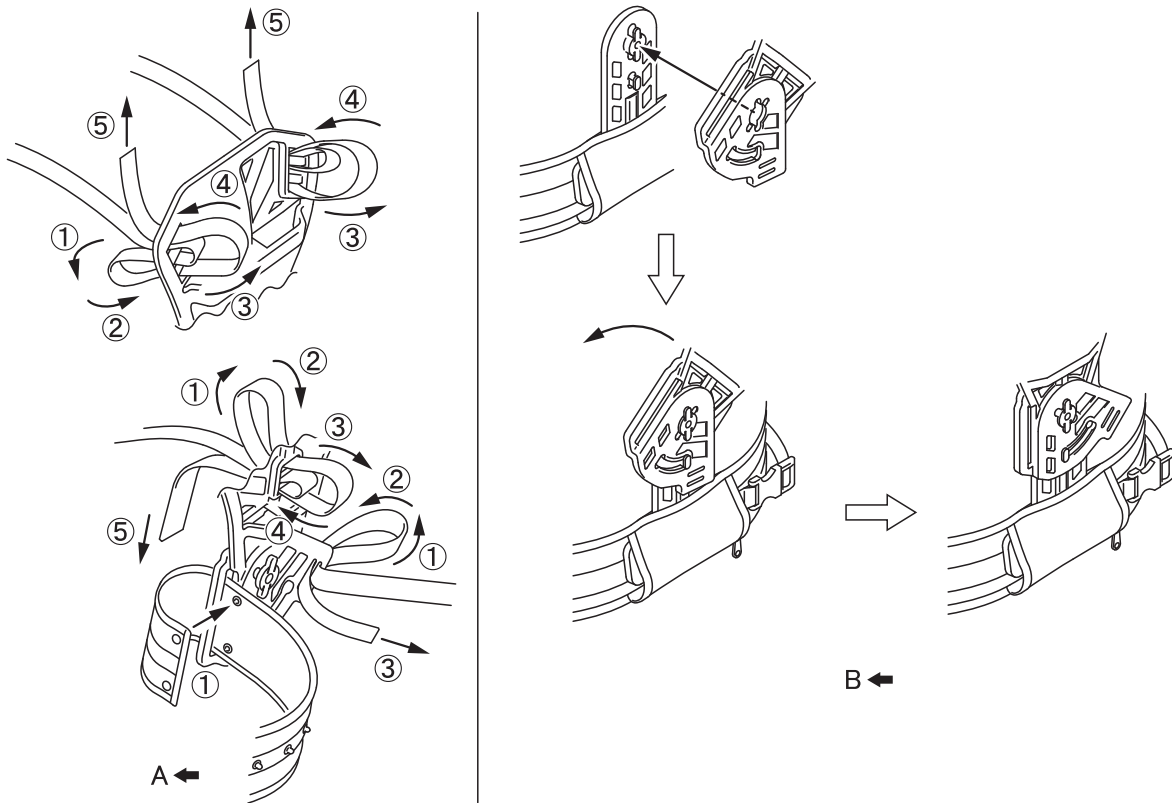

Before you start

Preparing the fuel

DANGER

- Do not fuel up while the engine is hot or in operation.
- Do not smoke or hold a flame near when refuelling.
If you do so, the fuel could ignite and cause fire, leading to burns.



WARNING

- Do not fill fuel tanks indoors. Always fill fuel tanks outdoors over bare ground. Do not refuel the product on the loading platform of a truck, or in other such places.
- Fuel tanks/cans may be under pressure. Always loosen fuel caps slowly allowing pressure to equalize. Otherwise, fuel may get spewed.
- Mop up any fuel that overflows or spills out due to overfilling.
Fuel spills can cause fire and burns when ignited.
- After refuelling, always check that there are no leaks or discharges of fuel from the fuel pipe, fuel system grommets, or around the fuel tank cap. If you do find fuel leaks or discharges, stop using the product immediately and contact your dealer to have it repaired.
Any fuel leaks could cause fire.
- Keep the refuelling tank in a shaded area away from fire.
- Use an approved fuel container.

IMPORTANT

- Fuel is a mixture of regular grade petrol and an air-cooled 2-stroke engine oil of reputable brand name. Minimum 89 Octane unleaded petrol is recommended. Do not use fuel containing methyl alcohol or more than 10 % of ethyl alcohol.
- Stored fuel ages. Do not mix more fuel than you expect to use in thirty (30) days.

Fuel



- ◆ Recommended mixture ratio; 50: 1 (2%) for ISO-L-EGD Standard (ISO/CD 13738), JASO FC,FD grade and ECHO Premium 50: 1 oil.
- ◆ Do not mix directly in engine fuel tank.

Fuel supply

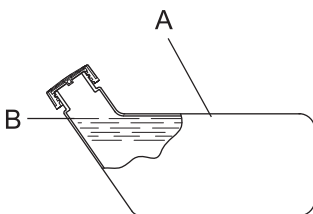

- ◆ Do not add so much fuel that it reaches the mouth of the fuel tank (A). Keep the fuel within the prescribed level (up to the shoulder level (B) of the fuel tank).
- ◆ Tighten the fuel tank cap securely after refuelling.

Engine operation

Starting the engine

WARNING

Be particularly careful to observe the following precautions when starting the engine:

- Move at least 3m from the place where you refuelled.
 - Place the product in a flat, well ventilated place.
 - Check that there are no fuel leaks.
 - Inspect metal blades for cracks.
 - Check that none of the nuts and bolts are loose.
 - Leave plenty of space around the product and do not allow people or animals near it.
 - Start the engine with the throttle trigger in the idle speed position.
 - Hold the product firmly to the ground when starting the engine.
- Failure to observe the precautions could cause an accident or injury, or even lead to a fatality.

- Check that there are no abnormal vibrations or sounds once the engine starts. Do not use the product if there are abnormal vibrations or sounds. Contact your dealer to have it repaired.

Accidents involving parts that fall or shatter off can cause wounds or serious injury.

- The exhaust fumes from the engine contain toxic gases. Do not operate the product indoors or in other ill ventilated places.

The exhaust fumes could cause poisoning.



- Do not touch silencer, spark plug, angle transmission, and other high temperature components while the product is running or for some time after it stops.

You could burn yourself if you touch a high temperature component.



- Do not touch spark plug, spark plug wire, and other high voltage components while the product is running.

You could receive an electric shock if you touch a high voltage component while the product is running.



- If the cutting attachment rotates even though the throttle trigger is in the idle speed position when the engine is started, adjust the carburettor before using the product.

Failure to observe the precautions could cause an accident or injury, or even lead to a fatality.

- When starting engine using throttle latch, cutting attachment rotates. After engine starts, pull throttle trigger slightly to release throttle latch immediately. Never use throttle latch for operation.

The rotating blade can cause injury.

NOTE

- Pull out the starter grip gently at first, and then more rapidly. Do not pull the starter rope out to more than 2/3 of its length.
- Do not let go of the starter grip as it returns.

Starting a cold engine

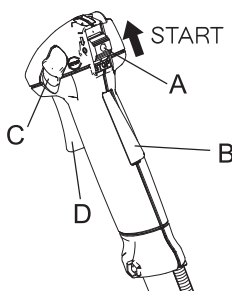

(Connect the spark plug cap if the product has been in storage for a long period of time.)

1. Remove the blade cover.
2. Placing the product on level ground, check to ensure that the cutting attachment does not come into contact with the surface of the ground or any other impediment using a beam or other such implement.
3. Move the ignition switch (A) to the Start position.
4. Make sure that the throttle trigger (D) is at the idle speed position.

Engine operation

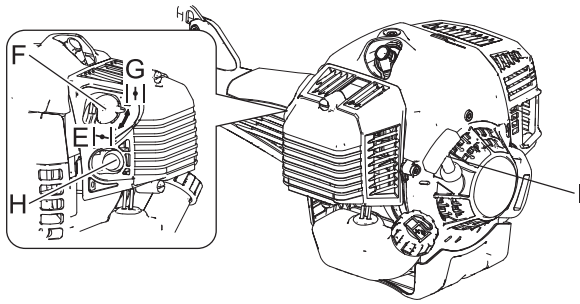

5. Move the choke lever (F) to the "Cold Start" (E) position.
6. Alternately press and release the purge bulb (H) until the fuel is sucked up into it.
7. Checking that the area around you is safe, hold the position closest to the engine firmly as shown in the illustration, pulling several times on the starter grip (I).
8. If you hear an explosion-like sound and the engine stops immediately, move the choke lever to the "Run" (G) position and continue pulling on the starter grip to start the engine.
9. If the engine does not stop, return the choke lever gently to the "Run" position.
10. Leave the engine to warm up at idle speed for a while.

- * When engine is hard to start, use throttle latch (C). (Pull throttle trigger fully and lower throttle latch while pressing throttle trigger lockout (B) and release throttle trigger to activate throttle latch. After engine starts, pull throttle trigger slightly to release throttle latch immediately.)

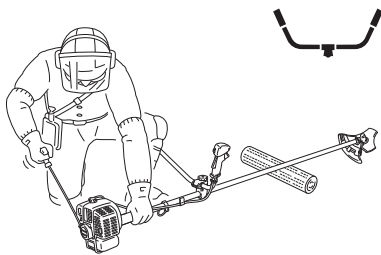

Starting a warm engine

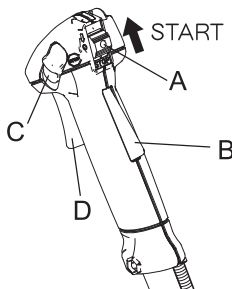

1. Move the ignition switch (A) to the Start position.
2. Make sure that the throttle trigger (D) is at the idle speed position.
3. Check that the choke lever is in the "Run" position.
4. If no fuel is visible in the purge bulb, alternately press and release the purge bulb until the fuel is sucked up into it.
5. Checking that the area around you is safe, hold the position closest to the engine firmly, and pull on the starter grip to start the engine.

Stopping the engine

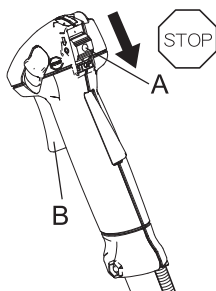

1. Move the throttle trigger (B) to the idle speed position and set the engine to idling (i.e. low speed).
 2. Move the ignition switch (A) to the Stop position.
 3. In the event of an emergency, stop the engine immediately using the ignition switch.
 4. If the engine fails to stop, move the choke lever to the "Cold Start" position. The engine will stall and come to a halt (an emergency stop).
- * If the engine fails to stop when the ignition switch is used, have the ignition switch checked and repaired by your dealer before you use the product again.
5. Always disconnect the spark plug wire from the spark plug to ensure the engine cannot be started before you work on the unit or leave it unattended.

Trimming operation

DANGER

- **Always stop the engine when a cutting attachment jam occurs.**
Severe injury can occur if a jam is removed and the cutting attachment suddenly starts.
- **Do not operate the product without the shield in place.**
Any objects that ricochet off the cutting attachment could cause an accident or serious injury.

- **The area within a 15 m radius of the product is a danger zone. Be careful to observe the following precautions while working with the product.**

- ◆ **Do not allow children and other people or pets to enter the danger zone.**
- ◆ **If another person enters the danger zone, turn off the engine to stop the cutting attachment from rotating.**
- ◆ **When approaching the operator, signal to him by, for example, throwing twigs from outside the danger zone, and then check that engine has been switched off and the cutting attachment has stopped turning.**
- ◆ **If more than one person is working with the product, identify the way in which you will signal to each other and work at least 15 m apart.**

Any objects that ricochet off the cutting attachment, and any contact with the cutting attachment, could cause blindness or a fatal accident.



WARNING

- **Before starting work, check the area where you will be working and remove any small stones and empty cans likely to ricochet off the cutting attachment, as well as any pieces of string or wire that might become twisted around the cutting attachment.**

An accident or serious injury can occur if foreign objects ricochet off the cutting attachment or wire and other materials twisted round the product spring off it.

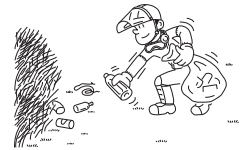

- **In the following situations, turn off the engine immediately and ensure that the cutting attachments have stopped before checking each area of the product. Replace any damaged parts.**

- ◆ **If the cutting attachment hits a rock, tree, post, or other such obstruction while you work.**
- ◆ **If the product suddenly starts to vibrate abnormally.**

Continuing to use parts when they are damaged could lead to an accident or serious injury.

- **Do not hold the cutting attachment up while you work. You must not work with the cutting attachments raised above knee level.**

Raising the cutting attachment above knee level brings the plane of rotation closer to the face, and any objects that fly off the cutting attachments could cause an accident or serious injury.

Transport of the product

- **When transporting in the situations described below, turn off the engine and ensure that the trimmer blade has stopped rotating, then fit the trimmer blade cover and position the silencer away from yourself.**

- ◆ **Moving to the place where you are working.**
- ◆ **Moving to another area while you are working.**
- ◆ **Leaving the place where you have been working.**

Failure to observe these precautions could cause burns or serious injury.

- **When transporting the product by car, empty the fuel tank, fit the blade cover, and secure the product firmly in place to prevent it from moving around.**

Travelling by car with fuel in the fuel tank could lead to a fire.

- **Never attempt to operate the product with one hand.**
- **Ensure that you hook your thumbs around the grips, wrapping them in your thumb and remaining fingers.**

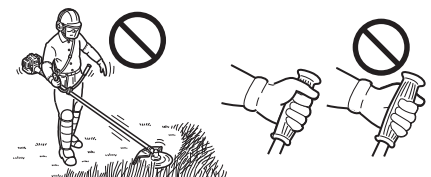

Trimming operation

Using shoulder harness

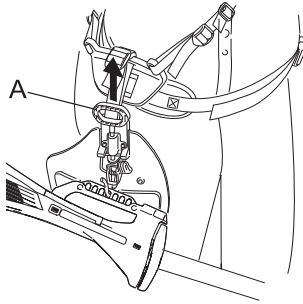

Always mount the trimmer correctly using the shoulder harness.

- ♦ Buckle waist belt. Belt should be snug.
- ♦ Attach product to harness.
- ♦ Place shoulder harness over both shoulders and adjust straps so the connecting point latches as shown.
- ♦ Check for correct adjustment by moving cutting attachment along ground.
- ♦ Re-adjust position of suspension point if necessary.
- ♦ The shoulder harness is fitted with an emergency release function. In the event of a fire or other emergency, pull the quick release pin (A) up to release the product from your body.

Basic trimming operation with nylon line cutting head

WARNING

- Serious injury may result from the improper use of cutting attachment. Read and comply with all safety instructions listed in this manual.
- Use only cutting attachments recommended by YAMABIKO Corporation.
- Excessive nylon line beyond cut off knife could fly off when the nylon line cutting head starts rotating after adjustment of nylon line length.
Failure to do so could lead to an accident or serious injury.

Trimming

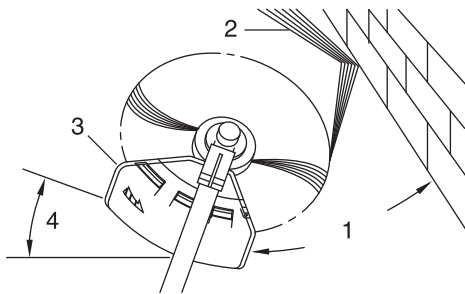

- ♦ This is feeding the trimmer carefully into the material you wish to cut. Tilt the head slightly to direct the debris away from you. If cutting up to a barrier such as a fence, wall or tree, approach from an angle where any debris ricocheting off the barrier will fly away from you.
 - ♦ Move the nylon line cutting head slowly until the grass is cut right up to the barrier, but do not jam (overfeed) the line into the barrier. If trimming up wire mesh or chain link fencing, be careful to feed only up to the wire. If you go too far, the line will snap off around the wire.
 - ♦ Trimming can be done to cut through weed stems one at a time. Place the nylon line cutting head near the bottom of the weed never high up, which could cause the weed to chatter and catch the line. Rather than cut the weed right through, just use the very end of the line to wear through the stem slowly.
1. Angle to wall
 2. Debris
 3. Knife side raised
 4. Angle to ground

Scything

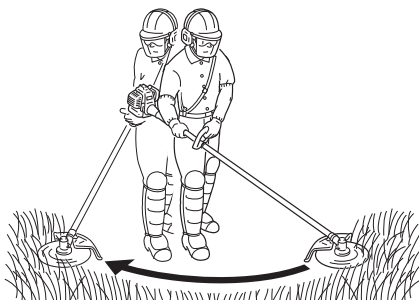

- ♦ This is the cutting or mowing of large grassy areas by sweeping or swinging the trimmer in a level arc. Use a smooth, easy motion. Do not try to hack or chop down the grass. Tilt the nylon line cutting head to direct the debris away from you on the scything stroke. Then return without cutting grass for another stroke. If you are well protected and do not care whether some debris is thrown in your direction, you may scythe in both directions.

Trimming operation

Scalping and edging

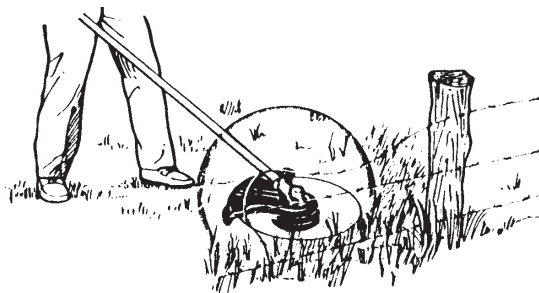
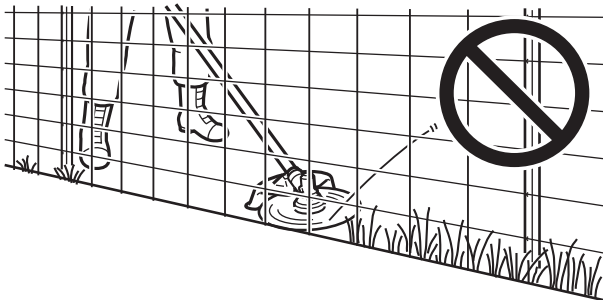
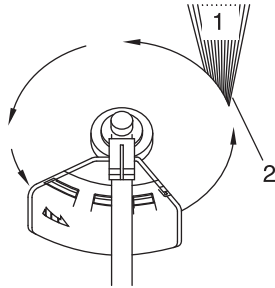
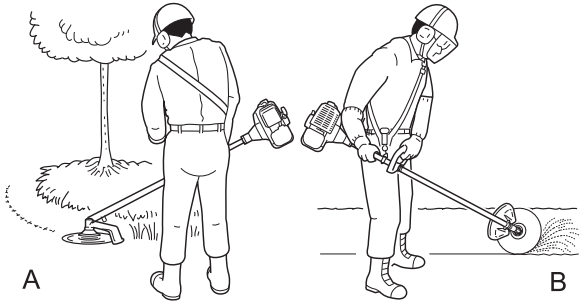

- ♦ Both of these are done with the nylon line cutting head tilted at a steep angle. Scalping (A) is removing top growth, leaving the earth bare. Edging (B) is trimming the grass back where it has spread over a pavement or driveway. During both edging and scalping, hold the unit at a steep angle in a position where the debris, and any dislodged dirt and stone, will not come back towards you even if it ricochets off the hard surface.
- ♦ Although the pictures show how to edge and scalp, every operator must find for himself the angles which suit his body size and cutting situation.

- ♦ For nearly all cutting, it is good to tilt the nylon line cutting head so that contact is made on the part of line circle where the line is moving away from you and the shield (See appropriate picture). This results in the debris being thrown away from you.
- ♦ Tilting the head to the wrong side will shoot the debris toward you. If the nylon line cutting head is held flat to the ground so that cutting occurs on the whole line circle, debris will be thrown at you, drag will slow the engine, and you will use up a lot of line.
- ♦ Nylon line cutting head rotates anticlockwise. The knife will be on the left side of the shield.

1. Debris
2. Cut on this side

- ♦ Do not push the line into tough weeds, trees, or wire fences.
- ♦ Pushing the line into chicken wire, chain link fencing or thick brush can result in snapped-off line ends being hurled back at the operator. The proper way is to cut right up to a barrier, such as any of those mentioned, but never run the line into or through the obstruction. Do not cut closely to obstruction or barrier.

- ♦ Avoid nylon line contact with broken wire fencing. Pieces of wire broken off by the trimmer can be hurled at high speeds.

Trimming operation

Basic trimming operation with metal blade

WARNING

- Please observe the following instructions when trimming.
 - ◆ Check to ensure that the trimmer blade has been tightened securely in place.
 - ◆ Replace the shield if it is damaged or cracked.
 - ◆ Replace the trimmer blade nut when it becomes worn.
 - ◆ Do not cut into the ground with the blade.
 - ◆ Do not operate with a dull, bent, fractured or discoloured blade and worn or damaged nut.
 - ◆ Do not run engine at full throttle without a load.

Failure to do so could lead to an accident or serious injury.

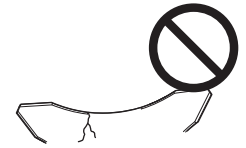

- Use only cutting attachments recommended by YAMABIKO Corporation.
- The type of blade used must be matched to the type and size of material cut. An improper or dull blade can cause serious personal injury. Blades must be sharp. Dull blades increase the chance of kick-out and injury to yourself and bystanders.
 - ◆ Plastic/Nylon Grass/Weed Blades may be used where ever the nylon line head is used. Do not use this blade for heavy weeds or brush.
 - ◆ The 3 cutter blade is designed especially to cut weeds and grass. To avoid injury due to kickback or blade fracture, do not use the 3 cutter blade to cut brush or trees.
 - ◆ 8 Tooth Weed/Grass Blade is designed for grass, garden debris and thick weeds. Do not use this blade for brush or heavy woody growth, 19 mm diameter or larger.
 - ◆ 22 Tooth Clearing Blade is designed for dense thickets and saplings up to 64 mm diameter.
 - ◆ 80 Tooth Brush Blade is designed for cutting brush and woody growth up to 13 mm diameter.

Damaged or shattered blades can cause accidents and serious injury.

Kickback

- The phenomenon that occurs if the trimmer blade comes into contact with a tree, post, rock or other hard object while rotating at high speed and reacts by recoiling powerfully and instantaneously is known as kickback.
- Causing kickback can result in a loss of control over the product and is highly dangerous.
- In particular, if the front-right quadrant of the trimmer blade (B) strikes a shrub or other such object, the trimmer blade will cause the product to recoil sharply backwards to the right.
- To prevent kickback, do not trim from left to right. Be careful to ensure that the trimmer blade does not strike any hard objects.
- When trimming, ensure that the object you are cutting meets the portion of the blade 1/3 in from the front edge on the left-hand side (A).

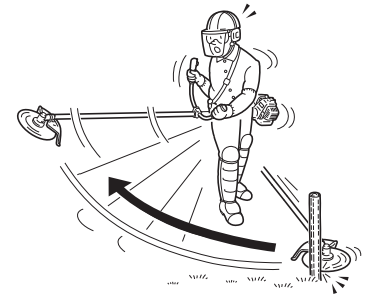
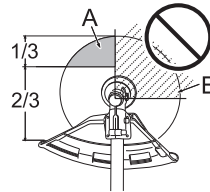

Failure to do so could cause an injury or fatal accident.

Scything weeds

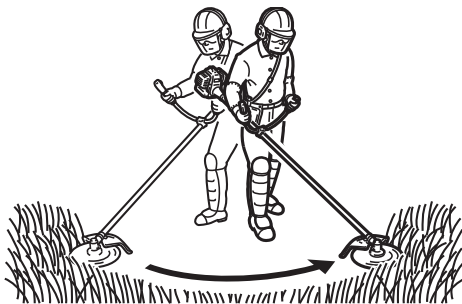

- ◆ This is cutting by swinging the cutting attachment in a level arc. It can quickly clear areas of field grass and weeds. Scything should not be used to cut large, tough weeds or woody growths.
- ◆ If a sapling or shrub binds the cutting attachment, do not use the cutting attachment as a lever to free the bind, because this will cause cutting attachment failure.
- ◆ Instead, shut off the engine and push the sapling or shrub to free the blades.

Maintenance and care

⚠ WARNING

Observe the following precautions when checking and maintaining your product after use:

- Turn the engine off and do not attempt to check or maintain the product until the engine has cooled.
You could burn yourself.
- Remove the spark plug cap before performing checks and maintenance.
An accident could occur if the product starts unexpectedly.

IMPORTANT

- Checking and maintenance requires specialist knowledge. If you are unable to check and maintain the product or deal with a fault yourself, consult your dealer. Do not attempt to dismantle the product.
- For spare parts and consumables, please use only genuine parts and designated products and components. Using parts from other manufacturers or non-designated components may result in a malfunction.

Servicing guidelines

| Area | Maintenance | Page | Before use | Monthly |
|------------------------|------------------------------|------|------------|---------|
| Air filter | Clean/Replace | 22 | • | |
| Fuel filter | Inspect/Clean/Replace | 23 | • | |
| Spark plug | Inspect/Clean/Adjust/Replace | 24 | | • |
| Carburettor | Adjust/Replace and adjust | 23 | | • |
| Cooling system | Inspect/Clean | 23 | • | |
| Silencer | Inspect/Tighten | 24 | • | |
| Silencer | Clean | 24 | | •** |
| Drive shaft | Grease | 25 | | •** |
| Angle transmission | Grease | 25 | | •* |
| Starter | Inspect | - | • | |
| Cut off knife | Inspect/Clean | - | • | |
| Fuel system | Inspect | 23 | • | |
| Screws, bolts and nuts | Inspect, Tighten/Replace | - | • | |

* Or 50 hours, whichever occurs first. ** Or 100 hours, whichever occurs first.

IMPORTANT

- Time intervals are maximum. Actual use and your experience will determine the frequency of required maintenance.

Maintenance and care

If you have any questions or problems, please contact your dealer.

Cleaning air filter

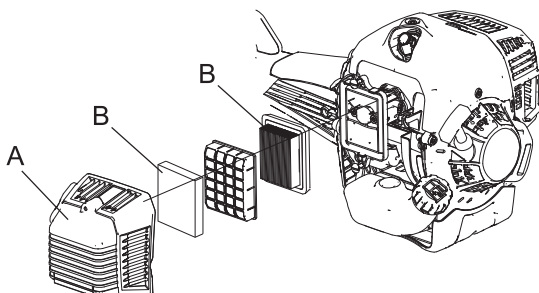

1. Close choke. Loosen screw and remove air cleaner cover (A).
2. Remove air filter (B) (air filter is located inside air cleaner cover).
3. Brush dirt from filter or clean with compressed air.
4. Reinstall filter.
5. Reinstall cover and tighten screw.

Maintenance and care

Replacing fuel filter

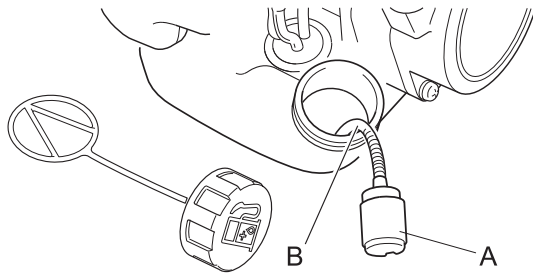

1. Use a piece of metal wire or the like to pick up fuel filter (A) through fuel tank opening.
2. Pull old filter from fuel line (B).
3. Install new fuel filter.

NOTE

- If filter is excessive dirty or no longer fits properly, replace it.

Carburettor adjustment

⚠ WARNING

- YOU MAY ADJUST THE IDLE SPEED ONLY by turning the idle speed adjustment screw (T).
- During carburettor adjustment, the cutting attachment may move. Pay utmost attention and care to the cutting attachment so as not to get injured by the moving cutter.
- When carburettor adjustment is completed, the cutting attachment should not move at idle speed, otherwise serious personal injury may result.
- You must NOT carry out any Carburettor adjustment, other than the idle speed. All other adjustments MUST be performed by an authorized service dealer, or serious personal injury may result due to malfunction of the engine.

⚠ CAUTION

- When there is trouble with the carburettor, contact an authorized service dealer.

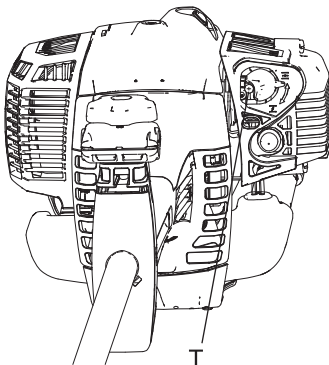

Every unit is test run at the factory and the carburettor is fine tuned for maximum performance.

Before adjusting carburettor, clean or replace air filter, start engine and run several minutes to bring it to operating temperature.

To adjust the carburettor proceed as follow:

Turn "idle" speed adjustment screw (T) clockwise until cutting attachment begins to turn, then turn screw(T) out anticlockwise until cutting attachment stops turning. Turn screw (T) out, anticlockwise, and additional 1 turn.

NOTE

When the carburettor cannot be adjusted properly with the idle speed adjustment screw (T), you must contact an authorized service dealer.

Cooling system maintenance

IMPORTANT

- To maintain proper engine operating temperature, cooling air must pass freely through the cylinder fin area. This flow of air carries combustion heat away from the engine. Overheating and engine seizure can occur when:
 - ◆ Air intakes are blocked, preventing cooling air from reaching the cylinder,
 - ◆ Dust and grass build up on the outside of the cylinder. This build-up insulates the engine and prevents the heat from leaving.

Removal of cooling passage blockages or cleaning of cylinder fins is considered "Normal Maintenance". Any resultant failure attributed to lack of maintenance is not warranted.

Maintenance and care

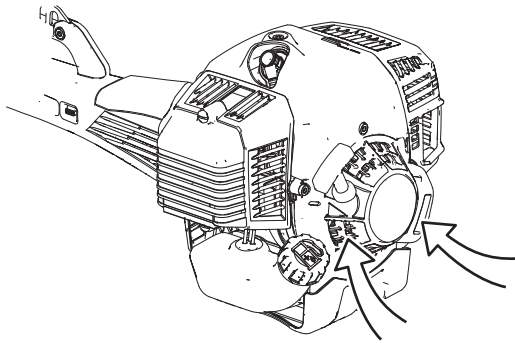

Air intake

- ♦ Keep dirt away from engine and air intake grid.

Cleaning silencer

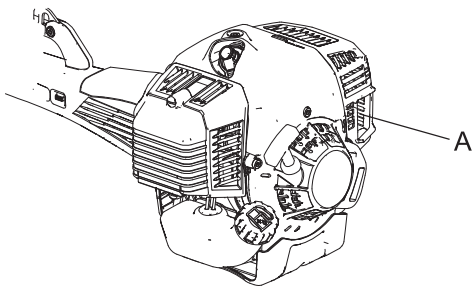

- ♦ Carbon deposits in silencer (A) will cause a drop in engine output and overheating. Clean deposits from silencer.

IMPORTANT

Do not remove the silencer cover. If necessary, Please consult your dealer.

Check fuel system

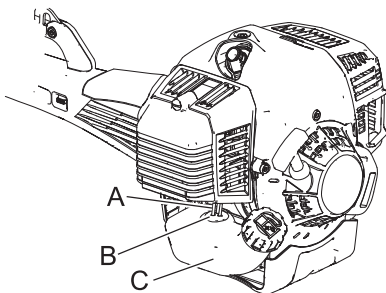

- ♦ Check before every use.
- ♦ After refuelling, make sure fuel does not leak or exude from around fuel pipe (A), fuel grommet (B) or fuel tank cap (C).
- ♦ In case of fuel leakage or exudation, there is a danger of fire. Stop using the machine immediately and request your dealer to inspect or replace.

Check spark plug

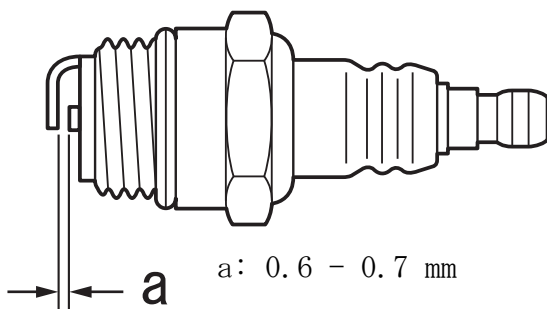

1. Check plug gap. Correct gap is 0.6 mm to 0.7 mm.
 2. Inspect electrode for wear.
 3. Inspect insulator for oil or other deposits.
 4. If the spark plug is dirty, clean it. Do not sandblast to clean. Remaining sand will damage engine.
 5. If the electrodes or terminals are worn, or if there are cracks in the ceramics, replace them with new parts. (see Specificationspage 28)
 6. Tighten to 15 N·m - 17 N·m (150kgf·cm to 170 kgf·cm).
- * The spark test (for checking whether the spark plug is sparking) must be carried out by your dealer.

Maintenance and care

Lubricating drive shaft

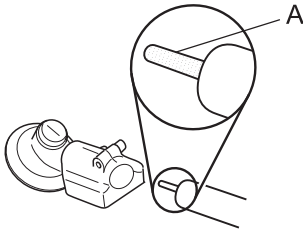

Inspect the drive shaft (A) every 100 hours of use and replenish grease if it is insufficient.

NOTE

- Use good quality lithium multi grease.

Angle transmission

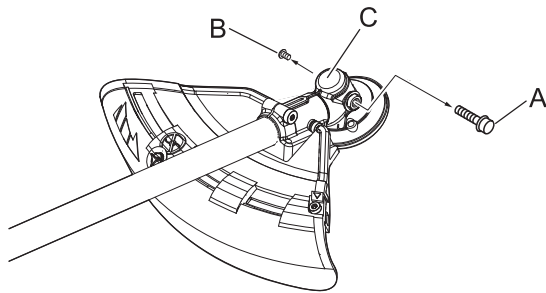

1. Remove the plug (A) and drain screw (B) from the angle transmission (C).
2. Add grease into the transmission until old grease is pushed out. If necessary, use a low pressure pump.

NOTE

- Use good quality lithium multi grease.

3. Reinstall the drain screw and plug.

Checking the blade

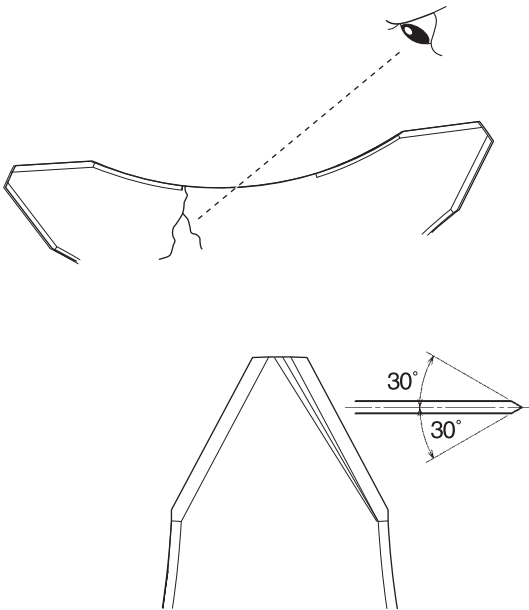

- ◆ Use only blade designated for this model by the manufacturer.
- ◆ When a crack is noticed on the blade, do not use it but replace with a new one.
- ◆ Ensure that the blade is correctly fitted in accordance with the instructions.

- ◆ When the cutting blade becomes dull due to wear reverse it for further use.
- ◆ When chip or bend occurs on the blade, vibration will increase. Replace with new one.
- ◆ When filing the blade file 3 cutting edges evenly using a flat file as shown in the illustration. Otherwise, the balance will be lost and vibration will increase.

Troubleshooting table

IMPORTANT

- For spare parts and consumables, please use only genuine parts and designated products and components. Using parts from other manufacturers or non-designated components may result in a malfunction.

Maintenance and care

| Problem | Diagnosis | Cause | Solution |
|--|---------------------------------------|--|--|
| The engine does not start | | <ol style="list-style-type: none"> 1. There is no fuel in the fuel tank 2. The stop switch is in the Stop position 3. Excess fuel suction 4. Electrical fault 5. Carburettor malfunction or internal sticking 6. Internal engine malfunction | <ol style="list-style-type: none"> 1. Fuel supply 2. Move to the Start position 3. Start the engine after servicing 4. Consult your dealer 5. Consult your dealer 6. Consult your dealer |
| Engine is difficult to start, fluctuating rotation | Fuel is entering the overflow pipe | <ol style="list-style-type: none"> 1. Fuel degradation 2. Carburettor problem | <ol style="list-style-type: none"> 1. Replace with new fuel 2. Consult your dealer |
| | No fuel is entering the overflow pipe | <ol style="list-style-type: none"> 1. Fuel filter is clogged 2. Fuel system is clogged 3. Internal carburettor parts sticking | <ol style="list-style-type: none"> 1. Clean or replace 2. Consult your dealer 3. Consult your dealer |
| | The spark plug is dirty or damp | <ol style="list-style-type: none"> 1. Fuel degradation 2. Incorrect electrode gap 3. Carbon deposits 4. Electrical fault | <ol style="list-style-type: none"> 1. Replace 2. Adjust or replace 3. Clean or replace 4. Consult your dealer |
| Engine starts but no acceleration is possible | | <ol style="list-style-type: none"> 1. Dirty air filter 2. Dirty fuel filter 3. Blocked fuel passage 4. Carburettor adjustment problem 5. Blocked exhaust vent or silencer vent | <ol style="list-style-type: none"> 1. Clean or replace 2. Clean or replace 3. Consult your dealer 4. Adjust 5. Clean |
| The engine stops | | <ol style="list-style-type: none"> 1. Carburettor adjustment problem 2. Electrical fault | <ol style="list-style-type: none"> 1. Adjust 2. Consult your dealer |
| The engine fails to stop | | <ol style="list-style-type: none"> 1. Stop switch malfunction | <ol style="list-style-type: none"> 1. Perform an emergency stop and consult your dealer |
| Cutting attachment rotates when the engine is idling | | <ol style="list-style-type: none"> 1. Carburettor adjustment problem 2. Damaged clutch spring | <ol style="list-style-type: none"> 1. Adjust 2. Consult your dealer |

- ♦ Consult your dealer in the event of a problem that is not covered in the table above, or other such concerns.
- ♦ Please contact your dealer in order to dispose of the product or its parts in compliance with national laws.

Manufacturer:

YAMABIKO CORPORATION

1-7-2 Suehirocho, Ohme, Tokyo 198-8760 JAPAN

Authorized Representative in Europe:

CERTIFICATION EXPERTS B.V.

Stationsplein 30, 1382AD Weesp, The Netherlands

Maintenance and care

Storage

Long-term storage (30 days or more)

WARNING

- **Do not store in sealed locations filled with fuel gas, or close to naked flames or sparks.**
You could cause a fire.



When storing the product for long periods of time (30 days or more), ensure that the following preparations for storage are carried out.

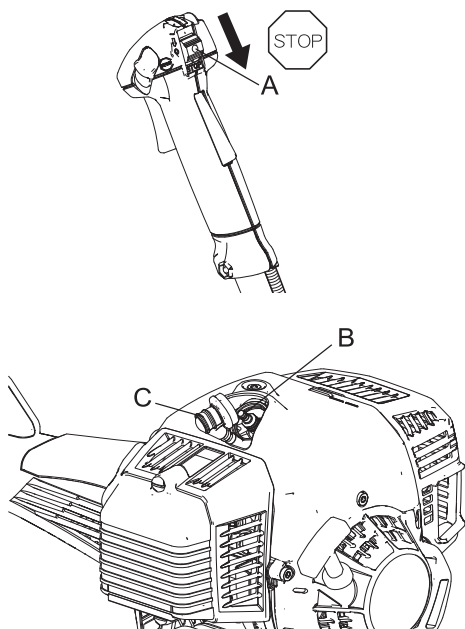

1. Remove any fuel from the fuel tank.
2. Alternately press and release the purge bulb a number of times to remove the fuel from the purge bulb.
3. Start the engine and run it at idle speed until it comes to a natural stop.
4. Move the ignition switch (A) to the Stop position.
5. Once the product is sufficiently cool, wipe clean any grease, oil, dust, dirt and other materials on the outside of the trimmer.
6. Perform the periodic checks prescribed in this manual.
7. Check that the screws and nuts are tightened. Tighten up any that are loose.
8. Remove the spark plug (B) and add the appropriate quantity (around 10 mL) of clean, new 2-stroke engine oil to the cylinder via the spark plug hole.
9. Place a piece of clean cloth over the spark plug hole.
10. Pull 2 or 3 times on the starter grip to distribute the engine oil into the cylinder.
11. Observe the piston location through the spark plug hole. Pull the recoil starter handle slowly until the piston reaches the top of its travel and leave it there.
12. Fit the spark plug. (Do not connect the spark plug cap (C).)
13. Fit the blade cover onto the trimmer blade and wrap the engine section in a plastic bag or other covering, and store in a dry, dust-free location out of reach of children.

Specifications

| | | SRM-520ES |
|--|--|--|
| External dimensions: Length × Width × Height | | 1835 × 705 × 595 mm * 1835 × 705 × 560 mm ** |
| Mass: Unit without fuel, cutting attachment and harness (ISO11806-1: 2011) Unit with fuel, specified cutting attachment, guard and harness Unit without fuel, cutting attachment, guard and harness | | 9.5 kg *, 9.3 kg ** 11.7 kg *, 11.7 kg ** 9.0 kg |
| Volume: Fuel tank (full) | | 690 mL |
| Fuel: Gasoline Oil Mixture ratio | | Regular grade petrol. Minimum 89 Octane unleaded petrol is recommended. Do not use fuel containing methyl alcohol or more than 10% of ethyl alcohol. Two stroke, air-cooled engine oil. ISO-L-EGD Standard (ISO/CD 13738), JASO FC,FD grade and ECHO Premium 50:1 oil. 50:1 part (2%) |
| Cutting attachment: Nylon line cutting head (Cutting swath) Thread Nylon cord size (diameter) Nylon cord length Type (Number of cutting teeth) Specified blade diameter Specified blade thickness Blade centre hole diameter | | DS-5 Left-handed thread M10×1.25 pitch 3.0 mm 3.0 m 3-cutter blade (3) 255 mm 3.0 m 25.4 mm |
| Gear Case: Gear ratio and lubrication Rotational direction of output shaft viewed from above maximum rotational frequency of the spindle | | 1.33 reduction and good quality lithium grease Anticlockwise 9250 r/min |
| Engine: Type Carburettor Magneto Spark plug Starter Power transmission Engine displacement Maximum shaft brake power (ISO 8893) Fuel consumption at maximum engine power Recommended maximum engine speed (With STD attachment installed) Recommended engine idling speed | | Air cooled two stroke, single cylinder Diaphragm type Flywheel magneto - CDI system NGK BPMR8Y Recoil starter Automatic centrifugal clutch 50.2 cm ³ 2.16 kW 1.23 L/h 11000 r/min *, 12000 r/min ** 2800 ±100 r/min |
| 2006/42/EC Vibration (ISO 22867) $a_{hv,eq}$ | Left handle Right handle Uncertainty K | 3.0 m/s ² *, 3.4 m/s ² ** 2.7 m/s ² *, 3.2 m/s ² ** 1.2 m/s ² *, 0.8 m/s ² ** |
| Sound pressure level (ISO 22868) L_{pAeq} | Uncertainty K_{pA} | 97.6 dB(A) *, 98.2 dB(A) ** 1.5 dB(A) *, 0.8 dB(A)** |
| Sound power level (ISO 22868) L_{WARa} | Uncertainty K_{WA} | 111.6 dB(A)*, 113.2 dB(A)** 2.1 dB(A)*, 1.6 dB(A)** |

* With nylon line cutting head, ** With metal blade

These specifications are subject to change without notice.

Declaration of conformity

The undersigned manufacturer:

YAMABIKO CORPORATION
1-7-2 Suehirocho
Ohme, Tokyo 198-8760
JAPAN

This declaration of conformity is issued under the sole responsibility of the manufacturer.

declares that the hereunder specified new unit:

GRASS-TRIMMER/BRUSHCUTTER

Brand: ECHO
Type: SRM-520ES

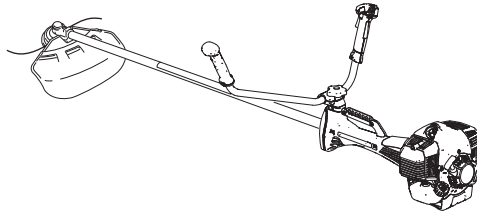

complies with:

- * the requirements of Directive **2006/42/EC** (use of harmonized standard **EN ISO 11806-1: 2011**)
- * the requirements of Directive **2014/30/EU** (use of harmonized standard **EN ISO 14982: 2009**)
- * the requirements of Directive **2000/14/EC**

Conformity assessment procedure followed **ANNEX V**

Measured sound power level: 113 dB(A)

Guaranteed sound power level: 116 dB(A)

Serial Number 26001001 to 26100000

Tokyo, September 1, 2018

YAMABIKO CORPORATION

Masayuki Kimura
General Manager
Quality Assurance Dept.

The authorized representative in Europe who is authorized to compile the technical file.

Company: CERTIFICATION EXPERTS B.V.

Address: Stationsplein 30, 1382AD Weesp, The Netherlands

Mr. Richard Glaser

YAMABIKO CORPORATION
1-7-2 Suehirocho, Ohme, Tokyo 198-8760 JAPAN
PHONE: 81-428-32-6118. FAX: 81-428-32-6145.



X750216-8001